



# SBC612

## 6U VPX QorIQ P4080-based Single Board Computer

### Features

- 6U VPX Single Board Computer
- P4080 processor
  - Eight e500mc cores @ up to 1.5GHz
- Dual-channel DDR3 (up to 8GB)
- 512MB NOR Flash
- 4GB NAND Flash Solid-State Drive
- 512kB non-volatile MRAM
- 4off x4 SRIO links from VPX P1
- 4off x4 PCIe Gen2 links from VPX P2
- 2x PMC/XMC Sites
- AFIX site (SCSI/VGA/1553/Flash drive)
- 2x 10/100/1000BASE-T Ethernet + 2x 10/100/1000BASE-T / 1000BASE-X
- 2x or 4x RS232 Debug
- 4x RS232/422/485 sync/async
- 2x Serial ATA (3 Gbit/s)
- 2x USB 2.0
- 19x Single-Ended GPIO (5V tolerant)
- Front I/O (air-cooled variants only)
- IPMI Baseboard Management Controller
- VITA65 OpenVPX Compatible
  - MOD6-PAY-4F1Q2U2T-12.2.1-2
  - MOD6-PAY-4F2T-12.2.2-1

The SBC612 is the first Freescale QorIQ-based product to join GE Intelligent Platform's VPXtreme6 family of rugged 6U VPX Single Board Computers.

Based on the P4080, the SBC612 offers a huge leap in processing performance, providing up to eight processing cores within the power envelope of previous dual core boards. Combined with an extensive and flexible range of I/O options, the SBC612 is ideal for a wide range of high performance Mil/Aero applications.

Features of the QorIQ P4080 processor:

- System on Chip (SoC) processor with eight high-performance e500mc cores built on Power Architecture Technology
- 45 nanometer technology delivers unprecedented performance per watt enabling power-efficient designs
- Quad and Octal-core options

Fully compatible with OpenVPX (VITA 65), the SBC612 offers dual high speed fabric connectivity (SRIO and PCI Express) enabling a range of scalable solutions from single host to large multiprocessor systems.

In addition the SBC612 supports a diverse I/O set that includes Gigabit Ethernet, fast serial COM ports, USB 2.0, SATA and GPIO. Further incremental system resource expansion is provided by two mezzanine

sites, both of which are XMC/PMC capable, and offer the option of having XMC I/O and/or PMC I/O routed to the VPX backplane connectors.

In addition an AFIX site is available for yet more plug-on system expansion. The AFIX site not only allows access to the current range of standard AFIX modules (graphics, SCSI, 1553, digital I/O, Flash memory) but also offers the opportunity to add customer-specific features at minimum cost and in the shortest timescales.

Designed specifically for harsh environments the SBC612 is ideal for Mil/Aero applications where high reliability and survivability are a must. Available in five air- and conduction-cooled ruggedization levels, the SBC612 also offers VITA48 formats for two-level maintenance (2LM) requirements.

For existing VPXtreme users, the SBC612 also offers a 'Technology Insertion' configuration which matches the pin-out of the existing SBC610 (no P2 connector).

The SBC612 is fully supported by comprehensive Deployed Test Software (BIT and BCS) with OS support planned for VxWorks®, LynxOS®, Open Source Linux®, and Integrity.



# SBC612 6U VPX QorIQ P4080-based Single Board Computer

## Specifications

### Integrated Host Processor

- Freescale QorIQ P4080 @ up to 1.5 GHz
- Eight e500 cores with private L1 and L2 caches
- Double-precision floating-point support
- 2 MB shared Level 3 cache
- CoreNet internal fabric @ up to 800MHz

### DDR3 SDRAM

- Up to 8 GB DDR3 SDRAM with ECC (4GB per bank)

### Flash Memory

- 512 MB NOR Flash memory
- Protected BANC Boot Area
- 4 GB NAND Flash SATA Solid State Drive

### Fabric

- Four x4 SRIO ports from VPX P1
- Four x4 PCI Express Gen 2 ports from VPX P2

### Mezzanine Sites

- Two XMC/PMC sites with x8 PCI Express or 64-bit PCI-X at up to 133MHz
- AFIX Site supporting GE daughter cards including dual-channel 1553, SCSI, Graphics and Flash Drive

### Gigabit Ethernet

- 4 x 10/100/1000BASE-T Ethernet
- Two ports may be used as 1000Base-X for in-system connectivity

### Rear I/O

- 2x/4x RS232 UART ports
- 4x RS232/422/485 async/sync ports
- 2x USB 2.0
- 2x Serial ATA (3Gbit/s) to P4
- Up to 19 5V-tolerant GPIO each capable of generating an interrupt.

### Front Panel I/O (Air-cooled boards only)

- Two connectors, each with serial, Ethernet and USB interfaces

### NVRAM / Real-Time Clock / Watchdog / ETI

- 512kB non-volatile MRAM
- Real-time clock with 1 second resolution
- 2 x Watchdog timers (programmable 32-bit timer)
- Elapsed Time Indicator (records power cycles and on-time)

### Temperature Sensors

- On-board ambient temperature

### Power Requirements

- Options for +5V or +12V main input power
- +3.3V AUX required
- +/-12V AUX only if required by mezzanine module

## Block Diagram

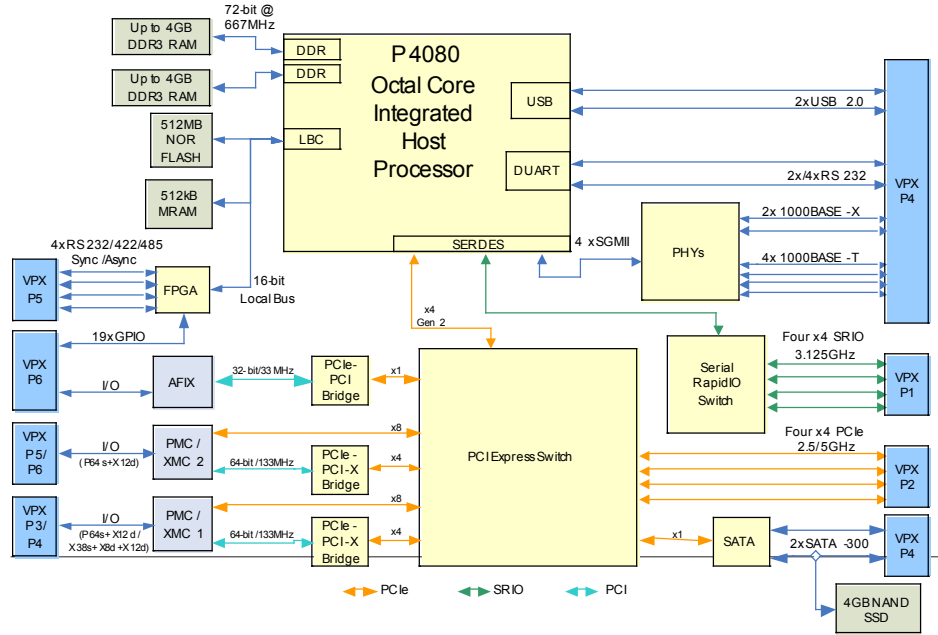

	Level 1	Level 2	Level 3	Level 4	Level 5
Cooling Method	Convection	Convection	Convection	Conduction	Conduction
Conformal Coating	Optional	Standard	Standard	Standard	Standard
High/Low Temperature Operational	0/+55C (300 ft/m)	-20/+65C (300 ft/m)	-40/+75C (600 ft/m)	-40/+75C (at cold wall)	-40/+85C (at cold wall)
Random Vibration	0.002g <sup>2</sup> /Hz*	0.002g <sup>2</sup> /Hz*	0.04g <sup>2</sup> /Hz**	0.1g <sup>2</sup> /Hz**	0.1g <sup>2</sup> /Hz**
Shock	20g***	20g***	20g***	40g***	40g***

\* from 10-2000 Hz \*\* with a flat response to 1000 Hz. 6 dB/Oct roll-off from 1000-2000 Hz \*\*\*PK Sawtooth 11 msec duration

## About GE Intelligent Platforms

GE Intelligent Platforms, a General Electric Company (NYSE: GE), is an experienced high-performance technology company and a global provider of hardware, software, services, and expertise in automation and embedded computing. We offer a unique foundation of agile, advanced and ultra-reliable technology that provides customers a sustainable advantage in the industries they serve, including energy, water, consumer packaged goods, government and defense, and telecommunications. GE Intelligent Platforms is a worldwide company headquartered in Charlottesville, VA and is part of GE Home and Business Solutions. For more information, visit [www.ge-ip.com](http://www.ge-ip.com).

## GE Intelligent Platforms Contact Information

Americas: 1 800 433 2682 or 1 434 978 5100

Global regional phone numbers are listed on our web site at [www.ge-ip.com/contact](http://www.ge-ip.com/contact)

[www.ge-ip.com](http://www.ge-ip.com)

