

SBC326

4th Generation Intel[®] Core™ i7 Based Rugged 3U VPX Single Board Computer

Features

- Single slot 3U VPX Single Board Computer
- 4th Generation Intel Core i7 quad core processor (6 MB shared cache)
- Two channels of soldered DDR3 SDRAM with ECC up to 16 GB
- Up to 32 GB NAND Flash
- XMC Site (x8 PCIe Gen 3 capable)
- Rear IO:
 - Up to 3 Gigabit Ethernet Ports (either one 1000BaseT plus two 1000BaseBX or two 1000BaseT)
 - 1x DVI / HDMI as standard (plus an additional DVI/HDMI port on some variants)
 - 1x SATA 6 Gb/s port as standard (plus additional two SATA 6 Gb/s ports on some variants)
 - 2x COM ports
 - 2x USB 2.0 ports (plus an additional USB 3.0 port on some variants)
 - Audio (available on some variants)
 - Up to 6x GPIO
- Five Levels of Ruggedization (Convection and conduction cooling variants)
- AXIS and Deployed Test Software
- Windows®, Linux® and VxWorks OS support

The SBC326 Rugged Single Board Computer (SBC) from GE Intelligent Platforms features the high performance, highly integrated 4th Generation Core i7 processor platform from Intel.

4th Generation Core i7 offers integrated graphics and memory controller plus quad core processing up to 2.4 GHz all in one device. Coupled with the Mobile Intel QM87 Express Chipset this provides an unmatched level of I/O bandwidth for both on-board and off-board functions.

Features of the 4th Generation Core i7

- Graphics support for DX11.1, OpenCL 1.2, OpenGL 3.2
- 5 to 15% CPU performance boost over 3rd generation
- Intel TurboBoost Technology
- Intel AVX 2.0 extensions and AES-NI instructions
- Hardware assisted security features
- Hyper-Thread Technology – 2 threads per core

In addition to a comprehensive range of onboard I/O features, the SBC326 also offers an on-board mezzanine expansion site for enhanced system flexibility.

Memory resources include up to 16 GB DDR3 SDRAM, up to 32 GB NAND Flash (SSD), 32 MB BIOS Flash and 16 MB BIOS backup Flash.

The SBC326 is designed to meet the requirements of a wide range of applications from industrial through to fully rugged Defense and Aerospace programs. It offers extended temperature capability and a range of air and conduction cooled build levels.

A rich software choice is planned for the SBC326, including comprehensive Deployed Test Software (BIT and BCS) and AXIS, plus OS support for Windows 7, Open Linux, Wind River Linux, VxWorks®.



SBC326 Intel 4th Generation Core i7 Based Rugged 3U VPX Single Board Computer

Specifications

Processor

- Intel 4th Generation Core i7 Processor
- i7-4700EQ (Quad Core) @ 2.4 GHz (47W) base frequency, up to 3.4 GHz TurboBoost
(Note: CPU speed is dependent on environment, consult manual for details)
- 22 nm monolithic die processing technology
- 6 MB Last Level Cache

SDRAM

- Up to 16 GB DDR3 SDRAM soldered with ECC

Non-Volatile RAM

- 512 kB FRAM

On Board Solid State Disk Drive (SSD)

- Up to 32 GB

BIOS

- 2x 16 MB SPI Flash for BIT and BIOS plus 1x 16 MB SPI Flash for Recovery

Data Plane / Expansion plane

- 8 lanes of Gen-3 capable PCI-Express to P1, can be configured as one x8 or two x4 ports
- PCIe REFCLK can be driven or received

Control Plane (Gig Ethernet)

- ETH0 is driven from QM87 (VPRO compliant) to P1 and is always configured as 1000BaseT
- ETH1 and ETH2 are routed to P1 and are configured as 1000BaseBX by default. Optionally ETH1 can be configured as 1000BaseT and ETH2 is then unused.

Management Plane

- Baseboard Management Controller (BMM) in accordance with VITA 46.11

USB Ports

- Two USB 2.0 ports (USB0, USB1) are routed to P1 connector and are available on all variants.
- One additional USB 3.0 port (USB2) is routed to P2 but shares pins with XMCIO – so is only available on selected variants

Serial Ports

- Two 165C50 compatible async serial ports are available on P1 and P2
- COM1 is 2-wire RS-232 port
- COM2 shares pins with GPIO lines and can be configured as a 2-wire RS-232 port, a 4-wire RS-232/422 port or as not present

XMC Site

- x8 PCIe Gen 3 capable
- Tracked as P2w1-X24s+X8d+X12d in accordance with VITA 46.9
- X12d is always available
- X8d shares pins with DVI2
- X24s shares pins with SATA1, SATA2 and USB2

Audio

- High Definition Audio Controller and Codec
- Stereo line in and stereo line out
- Available as an option in place of ETH0

Video

- One DVI / HDMI port (DVI0) routed to P2
- One additional DVI / HDMI port (DVI1) is routed to P2 but shares pins with XMCIO – so is only available on selected variants

SATA

- One SATA ports (SATA0) always available on P1
- Two additional SATA ports (SATA1, SATA2) are routed to P2 but shares pins with XMCIO – so is only available on selected variants
- All three ports are SATA6 Gb/s capable

Block Diagram

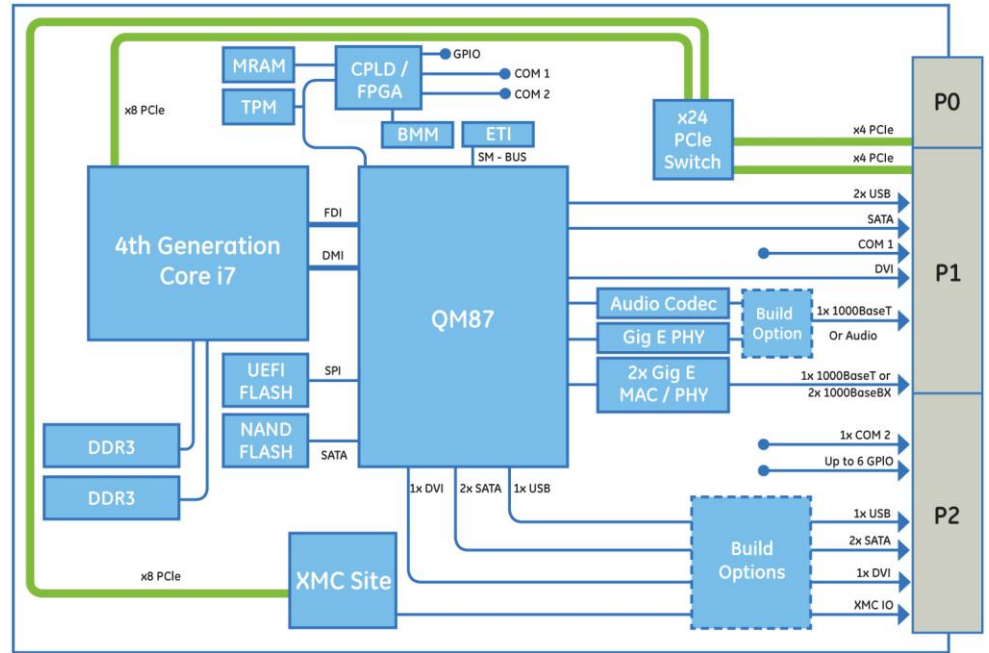

GPIO

- Up to 6 GPIO pins (5V Tolerant) all of which share pins with other functions – so number is dependent of variant selected

LED

- 3x status LEDs and four BIT status

Power Requirements

- +5V (Vs3) and +3.3V (Vs2) for main power
- +3.3V for P3V3_AUX is required
- +/-12V AUX only required for mezzanines

OpenVPX Profile Compatibility

- MOD3-PAY-2F2T-16.2.5-3 (Board configured for 2x 1000BaseT ports)
- MOD3-PAY-2F2U-16.2.3-3 (Board configured for 2x 1000BaseBX ports)

Watchdog/ Timers/ TPM / ETI

- Software programmable watchdog
- Timers in PCH (SW programmable)
- TPM (Trusted Platform Monitor)
- ETI (Elapsed Time Indicator)

Temperature Sensor

- PCB, CPU and PCIe Switch temperature sensors

Other HW Feature

- Hardware Write Protection

Transition Modules

- VPX3UX301 (3U high RTM for use with OpenVPX backplanes)
- VPX3UX601 (6U high for use in SCVPX3U starter cage)

Environmental

	Level 1	Level 2	Level 3	Level 4	Level 5
Cooling Method	Convection	Convection	Convection	Conduction	Conduction
Conformal Coating	Optional	Standard	Standard	Standard	Standard
High/Low Temp	0 to +55° C	-20 to +65° C	-40 to +75° C	-40 to +75° C	-40 to +85° C
Operational	(300 ft/m)	(300 ft/m)	(600 ft/m)	At cold wall	At cold wall
Random Vibration	0.002g ² /Hz*	0.002g ² /Hz*	0.04g ² /Hz**	0.1g ² /Hz**	0.1g ² /Hz**
Shock	20g***	20g***	20g***	40g***	40g***

*With a flat response to 1000 Hz, 6 dB/Oct roll-off from 1000 to 2000 Hz ** From 10 to 1000 Hz *** Peak sawtooth 11 ms duration
Note: Processor performance and temperature are inter-dependent. For a given temperature, a maximum speed is achievable, and conversely for a given processor speed a maximum temperature is achievable. Consult the product manual for details.

GE Intelligent Platforms Contact Information

Americas: 1 800 433 2682 or 1 434 978 5100

Global regional phone numbers are listed by location on our web site at defense.ge-ip.com/contact

defense.ge-ip.com

