



SBC620

6U Intel® Core™ 2 Duo VPX Single Board Computer

Features

- Intel® Core™2 Duo (Penryn) Processor @ 1.8 GHz
- Intel 5100 chipset (San Clemente)
- Up to 4 GBytes of DDR2 SDRAM with ECC
- 8 GBytes user flash memory
- Two PMC/XMC sites
- Four x4 PCI Express ports to the backplane for connection to fabric
- 6x USB 2.0 ports
- 2x SATA (3 Gbit/s ports)
- 2x Gigabit Ethernet
- 2x RS232/422
- Graphics controller
- Air and conduction cooled versions
- 6U VPX form factor (0.8" pitch)
- Optional covers for 2-level maintenance (0.85" pitch)
- Comprehensive Deployed Test software
- Comprehensive OS support

The VPXcel6 SBC620 is the latest member of the GE intelligent Platform growing portfolio of 6U VPX Single Board Computers targeted at the most demanding applications in embedded computing.

The SBC620's processor node features Intel's latest processors and server chipset, delivering impressive system level performance per watt. The Intel Core 2 Duo (Penryn) Processor is Intel's second generation dual core processor. This processor is designed to deliver low power and efficient breakthrough performance and responsiveness for demanding embedded market applications. The performance of this processor enables it to concurrently execute multiple threads and run multiple intense applications simultaneously.

The VPX form factor allows for high speed PCI Express connections to other cards in the

system. SBC620 supports this high speed I/O with the Intel 5100 chipset (San Clemente) providing superior on-board I/O paths in the form of four x4 PCIe lanes to the PMC/XMC expansion sites, and sends a x8 PCIe lane to a PCIe switch that routes four x4 PCIe lanes to the P1 backplane connector.

The SBC620 provides a number of high speed interfaces for off-board communication, including two Gigabit Ethernet ports, six USB 2.0 ports and two Serial ATA disk interfaces. In addition, there is support for legacy interfaces, including two RS232/422 ports, and eight general purpose I/O lines.

Available in five air- and conduction-cooled build levels, the SBC620 is fully supported by comprehensive Deployed Test Software (BIT and BCS) and OS support for VxWorks®, Windows® and Linux®.



SBC620 6U Intel® Core™ 2 Duo VPX Single Board Computer

Specifications

Processor - µFCBGA, Low Power Design

- Scalable processing power with flexible Processor
- Intel® Core™ 2 Duo (Penryn) Processor at 1.8 GHz
- Processor features include: Intel 64, Intel I/O Acceleration Technology, and Intel Virtualization Technology
- 6 MBytes L2 cache
- 1067 MHz system bus

DDR2 SDRAM

- 4 GBytes DDR2 SDRAM
- ECC Single Bit Correction
- ECC detection.
- 72-bit 667 MHz Memory Bus

Flash Memory

- 2 Mbytes FWH Boot flash
- 8 GBytes user flash memory
- Write-protection options via backplane

Fabric Interface

- Four x4 PCIe to the VPX backplane (configurable also as two x8 or one x8 and two x4)
- One XMC site supported by x4 PCIe interface
- One XMC site supported by an x8 PCIe interface

Gigabit Ethernet

- Two Gigabit Ethernet ports routed to P4

Graphics/Video

- Graphics support via the XGI Volari Z11 2D graphics controller
 - SBC620 supports Dual VGA graphics or VGA/DVI

Serial I/O

- Two RS232/422 (COM1 and COM2) routed to P4
 - RS232 signal levels standard, to operate ports In RS422 Is provided by the FPGA

General-Purpose I/O

- Eight general-purpose I/O (GPIO) lines each capable of generating an interrupt

USB

- Six USB 2.0 ports routed to either P4 or P6

SATA

- Two SATA ports routed to P4
 - Capable of operation at 1.5 GHz

PMC/XMC Expansion

- Two PMC/XMC expansion sites
 - Each site supports 5V PMCs
 - Each site Is connected to a 64-bit PCI bus capable of PCI-X operation at 133 MHz

Real-Time Clock/Watchdog/ETI

- Real-time clock
- Watchdog timer

Temperature Sensors

- CPU die and ambient temperature
- TPM

Power Requirements

- TBD

Environmental

- Level 1 - 5

Block Diagram

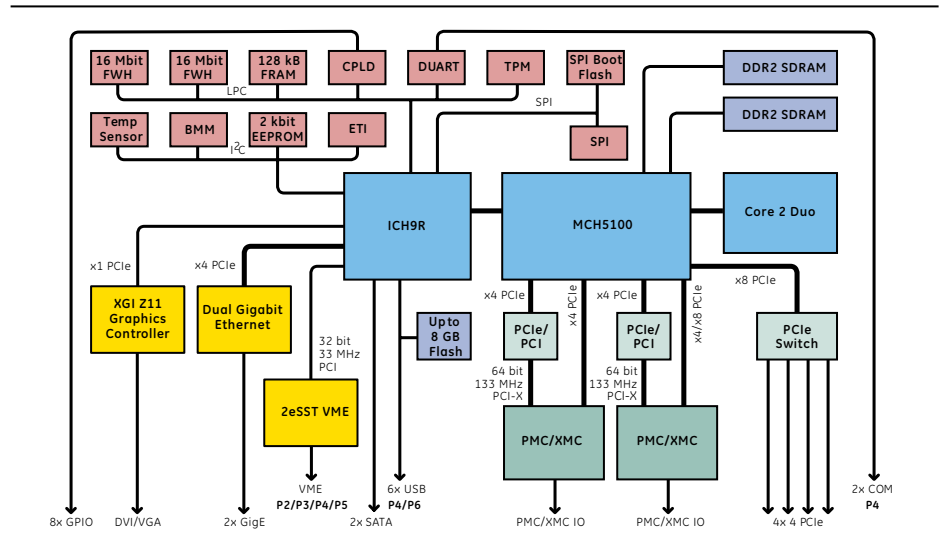

Environmental

	Level 1	Level 2	Level 3	Level 4	Level 5
Cooling Method	Convection	Convection	Convection	Conduction	Conduction
Conformal Coat	Optional	Standard	Standard	Standard	Standard
High/Low Temp	0° to 55°C	-20° to +65°C	-40° to +75°C	-40° to +75°C	-40° to +85°C
Operational	(300 ft/m)	(300 ft/m)	(600 ft/m)	at cold wall	at cold wall
Random Vibration	0.002g ² /Hz*	0.002g ² /Hz*	0.04g ² /Hz **	0.1g ² /Hz ***	0.1g ² /Hz ***
Shock	20g	20g	20g	40g	40g

* With a flat response to 1000 Hz. 6 dB/Oct roll-off from 1000 to 2000 Hz

** From 10 to 2000 Hz

*** Peak sawtooth 11 ms duration

About GE Intelligent Platforms

GE Intelligent Platforms, a General Electric Company (NYSE: GE), is an experienced high-performance technology company and a global provider of hardware, software, services, and expertise in automation and embedded computing. We offer a unique foundation of agile, advanced and ultra-reliable technology that provides customers a sustainable advantage in the industries they serve, including energy, water, consumer packaged goods, government and defense, and telecommunications. GE Intelligent Platforms is a worldwide company headquartered in Charlottesville, VA and is part of GE Home and Business Solutions. For more information, visit www.ge-ip.com.

GE Intelligent Platforms Contact Information

Americas: 1 800 433 2682 or 1 434 978 5100

Global regional phone numbers are listed by location on our web site at www.ge-ip.com/contact

www.ge-ip.com

