

# IPN250

## 6U GPGPU OpenVPX multiprocessor

### Features

- OpenVPX
  - 6U Rugged VITA46 / VITA48 REDI
- CPU
  - Intel® Core™2 Duo Penryn
- GPU
  - NVIDIA GT240 96 core GPU
- Multi-fabric data, expansion and control planes
  - 10 Gigabit Ethernet
  - PCIe switch on-board
  - 2 x 1000Base-T and 2 x 1000Base-BX
- Performance
  - 390 GFLOPS @ 100 watts

Note: actual performance is application dependent
- Software
  - BIOS, Linux, Windows®
  - NVIDIA CUDA™, OpenCL™, OpenGL
  - AXISLIB VSIPL Math & DSP libraries
  - NVIDIA PureVideo® Technology
  - NVIDIA PhysX™
  - Microsoft® DirectX (Compute)
  - MATLAB

IPN250 is the world's first GPGPU rugged, single slot, 6U OpenVPX and VITA48 REDI multiprocessor aimed at demanding defense and aerospace applications.

GE Intelligent Platforms' rugged, GPGPU COTS boards bring game-changing size, weight and power (SWaP) to a wide range of the most demanding deployed computing applications such as radar, sonar, sensor, video and image processing.

General Purpose computing on Graphics Processing Units (GPGPU) lets programmers solve problems in software that previously required dedicated FPGAs or ASICs.

With IPN250 and the new NPN240 (Dual NVIDIA GPU card), system integrators can accelerate application development while reducing cost and risk by leveraging the skills of a broad community of SW engineers across an expanding landscape of application development environments such as CUDA, OpenCL, OpenGL and MATLAB.

These boards are designed to scale from one to many GPGPU clusters, providing the flexibility to support real-time performance for a range of mission requirements at a fraction of the SWaP of conventional systems.

Building on more than 40 years experience supplying COTS boards to worldwide defense OEMs and integrators, GE Intelligent Platforms' new family of GPGPU platforms provide state of the art performance for DSP, general purpose, image and video processing by combining the latest CPUs from Intel's embedded road map with the very latest NVIDIA GPUs in one rugged board level module.

System integrators can deploy these platforms with confidence because IPN250 and NPN240 are the first in a family of rugged, 6U GPGPU COTS boards that will support the very latest chip level components from Intel and NVIDIA as they become available in the future.



# IPN250 – 6U GPGPU OpenVPX Multiprocessor

## Specifications

### Central Processing Unit:

- Intel® SP9300 Core™2 Duo Penryn @ 2.26GHz, Intel GM45 Express Chipset and ICH9M
- 64 bit data, SSE4 and 6 MBytes L2
- 8 GBytes DDR3 SDRAM (1066 MHz)
- 4 MBytes SPI FLASH
- 8 GBytes SATA FLASH Disk

### Graphics Processing Unit

- NVIDIA GT240 96 core GPU
- 1 GByte 128 bit wide DDR3 SDRAM, 1302 MHz shader, 790 MHz Memory, 540 MHz graphics

### Multi-fabric architecture

- P1 Data plane: 2x 10GE ports
- P2 Expansion plane: x16 PCIe gen 2
- P4 Control plane: 2x 1000Base-T and 2x 1000Base-BX

### CPU I/O

- GbE, 3x1 PCIe, 4x USB, 2x SATA, 2 COM Ports, 8x GPIO, Audio, TV input
- Front I/O: GbE, COM ports (levels 1 to 3 & 6)

### GPU I/O

- Dual link DVI, HDMI, 2 x VGA

### Form Factors

- 6U OpenVPX air, spray and conduction cooled builds
- 6U VITA48 REDI for 2LM

### Ruggedization

- Air cooled levels 1, 2 & 3
- Spray cooled level 6
- Conduction cooled levels 4 & 5

### OpenVPX

- SLT6-PAY-4F1Q2U2I-10.2.1
- MOD6-PAY-4F1Q2U2T-12.2.1-8

## Block Diagram

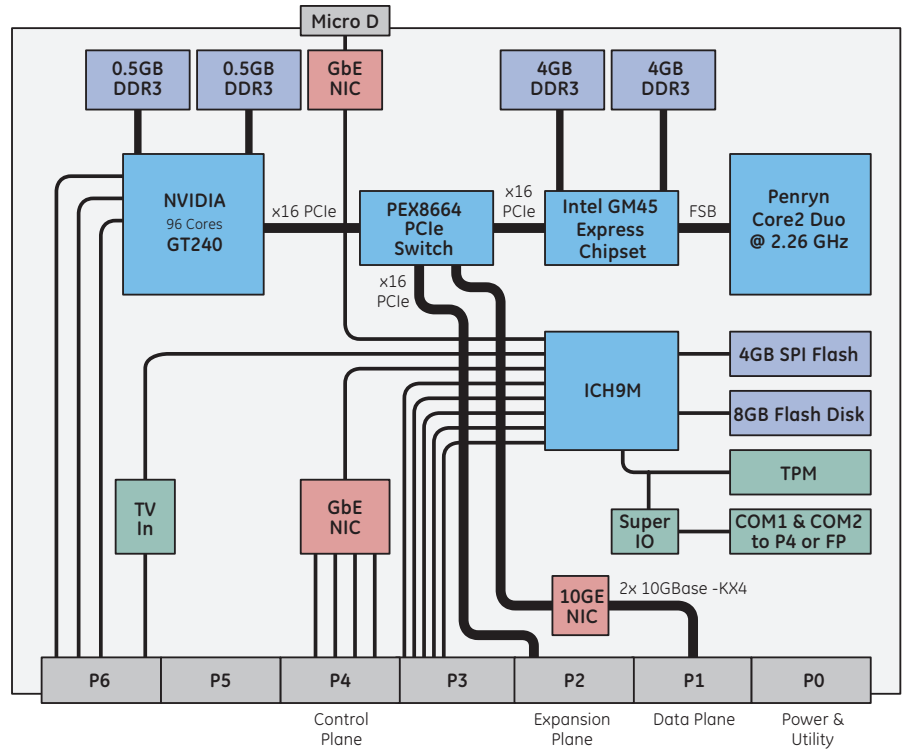

## Ordering Information

IPN250 - 1 1 2 2 0 0 1 3 = standard

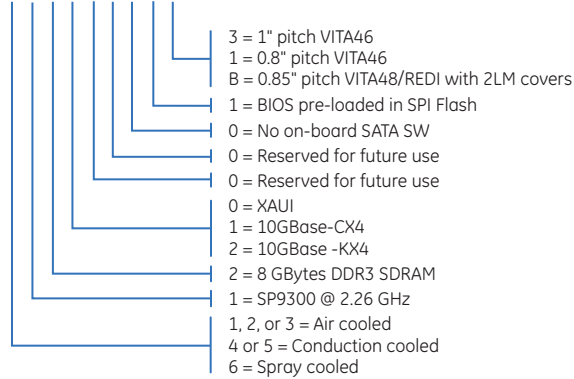

## GE Intelligent Platforms Contact Information

Americas: 1 800 433 2682 or 1 434 978 5100

Global regional phone numbers are listed by location on our web site at [www.ge-ip.com/contact](http://www.ge-ip.com/contact)

[www.ge-ip.com](http://www.ge-ip.com)

