

SBC341

3U VPX Intel® Core™2 Duo Single Board Computer

Features

- Intel® Core™2 Duo up to 2.26 GHz (Penryn)
- Up to 6 MB L2 cache
- Up to 8 GB DDR3 SDRAM
- 1066 MHz system and memory bus
- 1 GB Flash Disk
- Intel® GS45 Chipset
- x16 lane of PCIe to backplane for connection to graphics processor
- Additional x1 and x4 PCIe to the backplane
- Gigabit Ethernet
- 4x USB 2.0 ports
- 2x SATA
- Air and conduction cooled variants
- Operating System Support for Windows® XP, XP Embedded, Vista, Linux®, and VxWorks®

The SBC341 is a 3U VPX Single Board Computer based on the Intel® Core™2 Duo (Penryn) processor and is part of the VPXcel3 product family. This processor is 45nm micro architecture delivering superior performance and energy-efficiency.

SBC341 combines all this processing capability with the Intel GS45 memory controller with a DDR3 memory interface and connection to the ICH9M I/O controller providing: 2x serial ports, 4x USB 2.0, Audio in and out, and Gigabit Ethernet.

This single board is optimized for use in VPX systems with multiple PCI Express port options including a x16, x4, and x1. The x16 is designed to provide a dedicated communication path to a graphics processing unit, such as the GRA110. The x4 and x1 PCI Express ports allow high speed communication to other single board computers and I/O cards in order to build complex systems.

Alternatively, the 4-lane port can be configured as four single-lane ports.

If not using an off-board graphics processing unit, the GS45 utilizes its internal GMA 4500 graphics providing VGA video output. Stereo line-in and line-out capability provides audio support.

This single board computer is available in both air and conduction cooled variants.

Software support for:

- Windows XP, XP Embedded, and Vista
- Linux via installation disk
- RTOS support for VxWorks 6.6 from GE Fanuc
- Uses NVIDIA drivers for latest OpenGL and DirectX under Windows® and Linux®, and OpenGL drivers from GE Fanuc under VxWorks®



Optionally available as an LRM (Line Replaceable Module) in accordance with the VPX-REDI (formerly VITA 48) standard

SBC341 3U VPX Intel® Core 2 Duo Single Board Computer

Specifications

Processor

- Intel® Core™2 Duo Processor at 2.26 GHz (SP9300), or 1.86 GHz (SL9400)
- Penryn small form factor package processor
- 6 MB cache
- 1066 MHz system and memory bus

SDRAM

- Maximum memory configuration of 8 GB DDR3 SDRAM

Flash

- 1 GB on-board flash disk

BIOS

- System BIOS and Video BIOS are provided in reprogrammable flash memory.

Ethernet

- Gigabit Ethernet to the backplane

USB Ports

- Four USB 2.0 ports
- Supported USB features include: isochronous data transfers, asynchronous messaging, self-identification and configuration of peripherals, and dynamic (hot) attachment

VPX Backplane Interface

- Allows high speed PCI Express connections to other cards in the system.
- SBC340 supports:
 - One x16 PCIe from GS45
 - One each x1 and x4 PCIe from the ICH9M

Serial Ports

- COM1 and COM2

Serial ATA

- 2x SATA to the backplane

Audio

- Intel High Definition Audio
- Stereo line in and stereo line out

Video Controller

- GMA 4500 internal
- 16-lane PCIe for connection to external graphics card

Power Requirements

- TBD

MTBF

- Contact Factory

Block Diagram

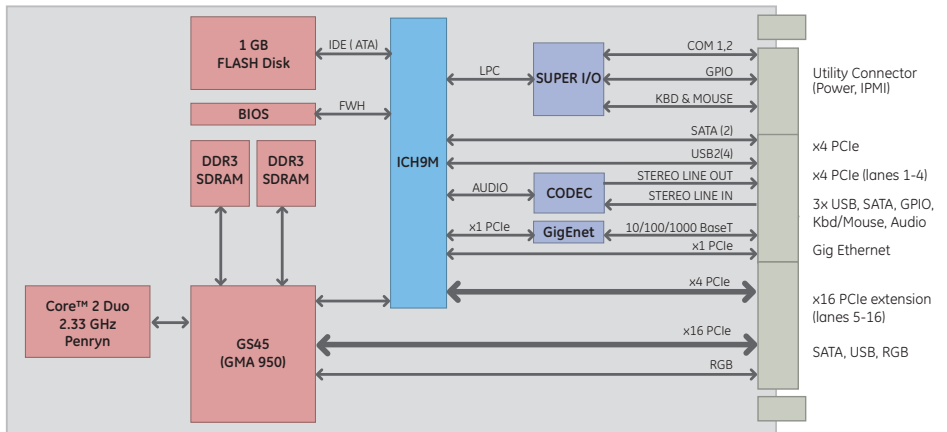

Environmental

	Level 1	Level 2	Level 3	Level 4	Level 5
Cooling Method	Convection	Convection	Convection	Conduction	Conduction
Conformal Coating	Optional	Standard	Standard	Standard	Standard
High/Low Temp	0 to 55°C	-20 to +65°C	-40 to +75°C	-40 to +75°C	-40 to +85°C
Operational	(300 ft/m)	(300 ft/m)	(600 ft/m)	At cold wall	At cold wall
Random Vibration	0.002g ² /Hz*	0.002g ² /Hz*	0.04g ² /Hz**	0.1g ² /Hz**	0.1g ² /Hz**
Shock	20g***	20g***	20g***	40g***	40g***

*With a flat response to 1000 Hz, 6 dB/Oct roll-off from 1000 to 2000 Hz

**From 10 to 1000 Hz

***Peak sawtooth 11 ms duration

About GE Fanuc Intelligent Platforms

GE Fanuc Intelligent Platforms, a joint venture between General Electric Company (NYSE: GE) and FANUC LTD of Japan, is an experienced high-performance technology company and a global provider of hard-ware, software, services, and expertise in automation and embedded computing. We offer a unique foundation of agile, advanced and ultra-reliable technology that provides customers a sustainable advantage in the industries they serve, including energy, water, consumer packaged goods, government and defense, and telecommunications. GE Fanuc Intelligent Platforms is a worldwide company headquartered in Charlottesville, VA and is part of GE Enterprise Solutions. For more information, visit www.gefanuc.com.

GE Fanuc Intelligent Platforms Information Centers

Americas:
1 800 322 3616 or 1 256 880 0444

Asia Pacific:
+81 3 5544 3973

EMEA:
Germany: +49 821 5034-0
UK: + 44 1327 359444

Additional Resources

For more information, please visit the GE Fanuc Intelligent Platforms web site at:

www.gefanuc.com

