

## IC-FEP-VPX3a

### Xilinx Virtex-5 3U VPX board with FMC Site

**IC-FEP-VPX3a** is powered by a Xilinx Virtex-5 SX95T.

Designed for applications requiring a very high level of computing power in a compact 3U form factor, the **IC-FEP-VPX3a** board mixes the flexibility of a Virtex-5 FPGA and the VPX high bandwidth serial interfaces.

A FMC mezzanine site enlarge the adaptability of the board to connect ADC, DAC, general IOs, video, sFPDP or additional FPGA FMC modules.

As part of our 3U VPX range, the **IC-FEP-VPX3a**, associated with our Intel® or Freescale SBCs and with our XMC carrier supporting IOs boards, provides the ideal platform for radar, sonar, electronic warfare and other digital signal processing applications.

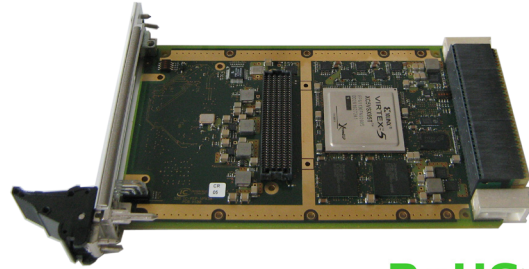

**RoHS** ✓  
2002 / 95 / EC

#### Description

The Virtex®-5 FPGAs used on the **IC-FEP-VPX3a** are parts of the Xilinx 65nm FPGA family, fabricated in 1.0v, triple-oxide process technology.

The board is equipped with a Virtex®-5 SX95T providing :

- DSP48E slices : 640
- Virtex-5 Slices : 14720
- BlockRAM : 244

The Fabric Links of the VPX backplane, connected to the FPGA, allow data rate of 2,5 Gbps or 3,125 Gbps per lane, depending on the type of the interface (PCIe or Aurora - SRIO available thanks to specific IP).

As an option, It is possible to take advantage of the embedded 10/100/1000 MAC block IP to provide two Ethernet 1000BASE-KX ports on the backplane.

The FMC site is fully compliant with the FPGA Mezzanine Card standard (VITA 57.1), allowing to install FMC modules provided by IC, third-party or developed by the customers. These mezzanine modules will authorize to systematically use the latest / best suited high resolution A/D components in regards of the needs.

The **IC-FEP-VPX3a** is a VPX 3U / 4HP (0.8") board compliant with 3U module definitions of the VITA 46.0 standard.

It is available in standard, rugged and conduction-cooled grades.

#### Main features

##### Processing Unit

- ▶ Xilinx virtex-5 XC5VSX95T
- ▶ One DDR2 controller : 32-bit wide, 256MBytes
- ▶ Two QDR2 controllers : 36-bit wide with 4MBytes (each)
- ▶ configuration flash :
  - one parallel Flash (16MByte)
  - two SPI flash (2\*16MBytes)

##### VPX Interfaces

- ▶ three 4-lanes Fabric ports (on P1)
  - one PCIe x4 (port A)
  - two GTPx4 (ports B & C)
- ▶ two 1-lane ports (on P1)
  - a dual GTPx1 link usable as 2 1000BASE-KX ports
- ▶ General purpose IOs (on P2)
  - eight single-ended IOs
  - sixteen differential pairs
- ▶ One RS232 on P1 (Rx/Tx LVTTTL)

##### FMC interfaces

- ▶ one GTPx4 link (limited to x2 when the dual GTPx1 link used on P1 - user configuration)
- ▶ 68 differential pairs

##### Accessories

- ▶ Engineering kit for debug (JTAG)

# IC-FEP-VPX3a

XILINX Virtex 5 3U VPX board with FMC site

## On-board firmware

The IC-FEP-VPX3a hardware platform is compatible with the Xilinx development tools (ISE Design Suite, Platform cable...).

Interface Concept provides VHDL code for system services (DDR2, QDR2, PCIe, Aurora). Their implementation requires the Xilinx ISE Design Tools. Integration from Xilinx System Generator will be available soon.

The customers implement their own realtime applications with the capability to integrate the existing openSource code or third-party IP cores.

## Interface features

### P1 connector

- ▶ three 4-lanes Fabric ports
  - one PCIe x4 (port A)
  - two GTPx4 (ports B & C)
- ▶ two 1-lane ports
  - a dual GTPx1 link usable as 2 \* 1000BASE-KX ports
- ▶ One RS232 on P1 (Rx/Tx LVTTTL)

### P2 connector

- ▶ General purpose IOs (on P2)
  - eight single-ended IOs
  - sixteen differential pairs

### FMC connector

- ▶ one GTPx4 link (limited to x2 when the dual GTPx1 link used on P1 - user configuration)
- ▶ 68 differential pairs

## Block Diagram

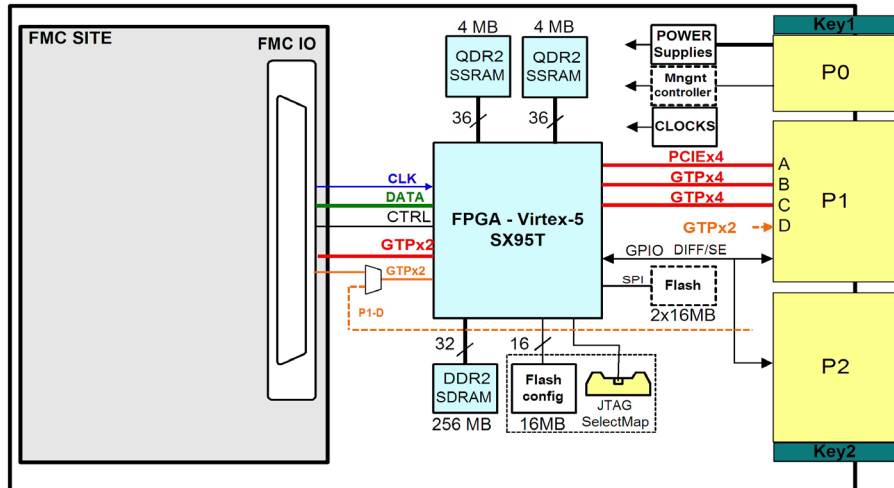

## FMC modules

Interface Concept provides FMC modules

### IC-DAC-FMCa :

- ▶ Quad 16-bit 800 Msp DAC

### IC-ADC-FMCa :

- ▶ Quad 16-bit 135/200 Msp ADC

### IC-ADC-FMCb :

- ▶ Quad 14-bit 250 Msp ADC

Please consult us for technical details and availability.

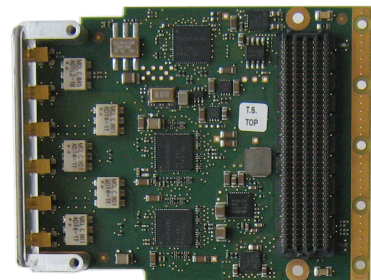
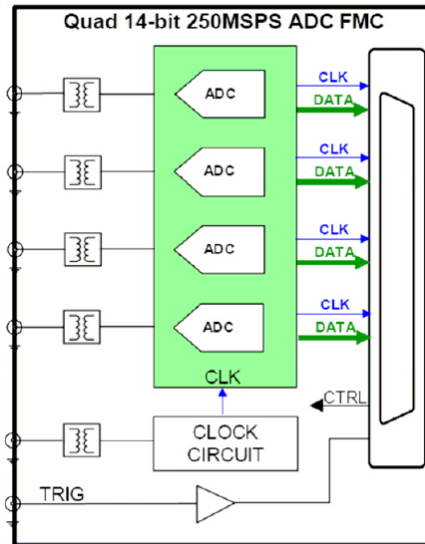

## Environnement Specifications:

Please consult the IC-FEP-VPX3a page at [www.interfaceconcept.com](http://www.interfaceconcept.com).

## Ordering Information:

Please contact our sales department : tel. +33 (0)2 98 573 030 - email : [info@interfaceconcept.com](mailto:info@interfaceconcept.com)

This document supersedes any earlier documentation relating to the products referred to herein. The information contained in this document is current at the date of publication. It may subsequently be updated or withdrawn without notice.

