

3U VPX BACKPLANE
VITA 46



Key figures:

- Compliant to VITA 46.0 baseline specification
- Supports VITA 46.4 Full Mesh X1 PCI Express
- Supports VITA 46.10 with RTM connectors
- 3U, 5 Slot, Full Mesh configuration
- M4 screws and ATX 24 poles connector for powerentry
- PCB size 128,5mm x 120,7mm x 5,4mm
- 4 HP from slot to slot (20,32mm)
- System Management Interface on the backplane (I²C1, I²C2)
- Flexible keying and alignment mechanism
- with JTAG connector on first slot
- with geografical address pins
- Reference clock
- Non-Volatile Memory Read Only signal set by Jumper BR1
- Battery backup option setting by Jumper X5. Vbat external or connected to 3.3 AUX.
- System Reset
- P1 Reserved Signals
- Operating temperature: -40° - +85°C
- Storage temperature: -55°C - +85°C
- Flammability rating: UL94-V0

- Partnumber: 2.K2305010

- 4 Slot VPX Backplane also available. Partnumber: 2.K2304010

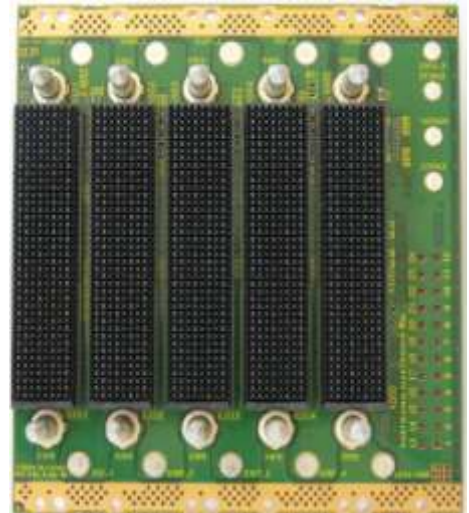
Frontside



Rearside

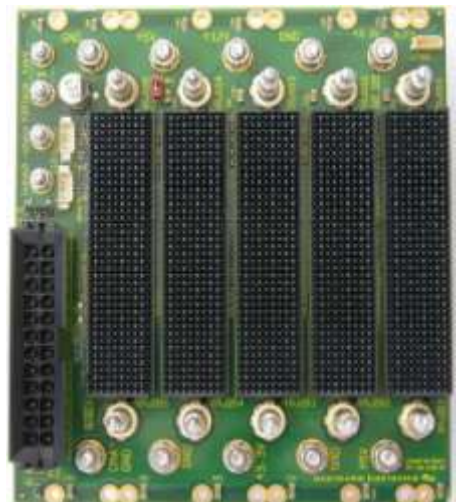

3U VPX BACKPLANE

VITA 46



1) Topology: Full Mesh X1

Frontside

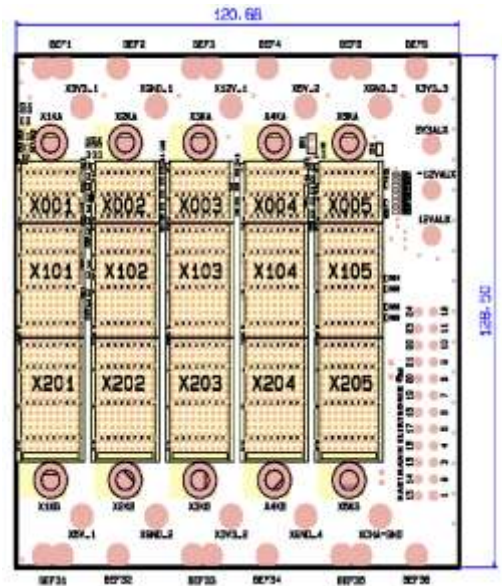
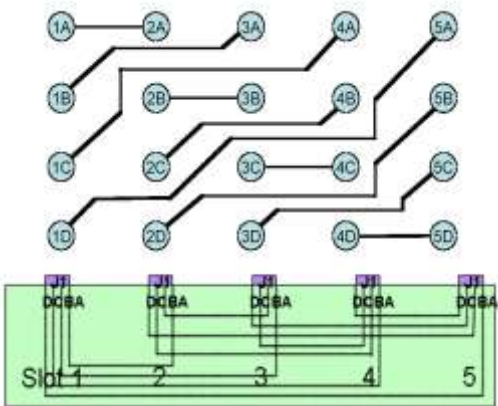

Rearside

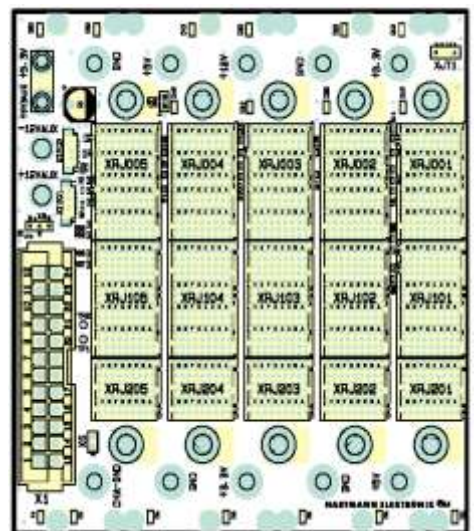

2) Current Capability:

(By using ATX connector see values in brackets)

- +12V 40 A (10 A)
- +3.3V 80 A (20 A)
- +5V 80 A (25 A)
- -12V AUX 5 A
- +12V AUX 5 A
- +3.3V AUX 5 A

Consider: Max. 36A/ Slot acc. VITA 46.0 allowed

3U VPX BACKPLANE	VITA 46	

3) System Management IPMB (I2C1, I2C2 connector):

There are 2 connectors (5 poles) for system management I2C1, I2C2.

I2C1	Signal
1	SCL1
2	GND
3	SDA1
4	+3.3V_AUX
5	

I2C2	Signal
1	SCL2
2	GND
3	SDA2
4	+3.3V_AUX
5	



4) VBAT (X5 connector):

Normally a battery voltage with approximately 3V is available at Pin VBAT of connector VPX-J1. The voltage is externally accessible with connector X5. The battery should be connected to pin 1 and 2 or internally using 3.3V_AUX by closing a Jumper between pin 2 and 3.

X5	Signal
1	GND
2	VBAT
3	+3.3V_AUX

5) NVMRO (BR1 Jumper):

If Jumper BR1 is closed NVRMO is set to memory writeable.

BR1	Signal
1	NVMRO
2	GND



3U VPX BACKPLANE	VITA 46	

6) JTAG (connector XJT1)

For test and programming a JTAG connector (6-poles) is implemented (XJT1).

XJT1	Signal
1	GND
2	TCK
3	TMS
4	TRST-
5	TDI
6	TDO



7) Power connection (X1 or M4 screw):

The main operating voltages and GND are supplied with M4 screw terminals or connector X1 (fits to ATX connector without locking mechanism). The auxiliary operating voltages are supplied via M3 screw terminals. Optimal daughter board supply and trouble-free operation are ensured by the arrangement of the feed modules on the backplane.



X1	Signal	Signal	X1
1	+3.3V	+3.3V	13
2	+3.3V	-12V	14
3	GND	GND	15
4	+5V	PS_ON	16
5	GND	GND	17
6	+5V	GND	18
7	GND	GND	19
8	PWR_OK	Res	20
9	+5VSB	+5V	21
10	+12V	+5V	22
11	+12V	+5V	23
12	+3.3V	GND	24

If Jumper X6 is closed ATX power supply starts automatically.

Germany

HARTMANN ELEKTRONIK GmbH
 Motorstr. 43
 D-70499 Stuttgart
 Phone: +49 711 13 98 90
 Fax: +49 711 8 66 11 91
info@hartmann-elektronik.de
www.hartmann-elektronik.de

USA

Hartmann Electronic
 Scott Puderbaugh
 300 East Auburn Avenue
 Springfield, OH 45505
 Phone: 937-324-4422
 Fax: 937-324-2425
 Mobile: 937-215-5313
Scott.Puderbaugh@hartmann-electronic.com
www.hartmann-electronic.com

France

HARTMANN ELEKTRONIK France
 Serge PICHAT
 14 chemin de Presles
 69540 IRRIGNY (FRANCE)
 Phone: +33 9 66 44 03 15
 Mobile: +33 6 82 62 16 00
serge.pichat@hartmann-elektronik.fr

India

Phoenix Mecano (India) Ltd.
 Mr. Vivek Deshpande
 388 Bhare, Taluka Mulshi,
 Post Gotawade, Pune - 412 108
 Phone: +91 20 66 74 52 36
 Fax: +91 20 22 92 92 05
vivek@pmipi-online.com
www.phoenixmecano.in