

# PPC9B

## 6U VMEbus QorIQ P2020 based Single Board Computer

### Features

- Freescale QorIQ P2020 processor up to 1.2 GHz
  - Two e500 cores
  - Shared 512 KB L2 Cache with ECC
  - Integrated DDR3 memory controller with ECC
- Up to 2 GByte soldered DDR3 SDRAM with ECC
- Up to 1 GByte Flash
- 2x128 KB of NVRAM
- Two on-board expansion sites
  - One XMC/PMC and one PMC only
- Front IO (Air-cooled versions)
  - 1x Gigabit Ethernet
  - 1x USB 2.0
  - 1x UART port
- Rear IO
  - 2x Gigabit Ethernet
  - 2x UART ports
  - 4x fast serial COM ports
  - 5x USB 2.0 ports
  - Keyboard & Mouse or 2 more USB 2.0 ports
  - 2x SATA ports
  - 25x GPIO
  - XMC / PMC / AFIX I/O
  - 2eSST VME
  - AXIS timer
- Operating System Support for VxWorks®, LynxOS®, Open Source Linux®
- Single slot 6U VMEbus form factor

The PPC9B is the first Freescale QorIQ based single board computer to join the PowerXtreme family of rugged 6U VMEbus processors. By preserving the same hardware interfaces as previous PowerXtreme family members, the PPC9B provides an ideal opportunity for state-of-the-art technology insertion into both upgrade programs and new platforms alike. But for the first time a dual core Single Board Computer is now available in the power envelope of previous single core solutions.

### Features of the QorIQ P2020 processor

- System on Chip (SoC) processors with high-performance e500 cores built on Power Architecture Technology 45 nanometer technology delivers unprecedented performance per watt enabling power-efficient designs
- Dual- and single-core products

The PPC9B's P2020 based processor node supports a comprehensive range of high capacity memory resources including DDR3 SDRAM, Flash, and NVRAM.

In addition the PPC9B also supports a diverse I/O set that includes options for legacy features such as keyboard and mouse, parallel port and floppy interface, which are ideal for upgrade programs, as well as more current options such as Gigabit Ethernet, fast serial COM ports, USB 2.0, SATA and GPIO.

The PPC9B provides two mezzanine sites for incremental system resource expansion. One site is an XMC/PMC site, offering the option of having XMC I/O or PMC I/O routed to the P0 connector. The second site offers PMC capability, including 5V tolerance, with its I/O pins mainly routed to the P2 connector

In addition an AFIX site is available for yet more plug-on system expansion. The AFIX site not only allows access to the current range of standard AFIX modules (graphics, SCSI, 1553, digital I/O, Flash memory) but also offers the opportunity to add customer-specific features at minimum cost and in the shortest timescales.

Designed specifically for harsh environment applications the PPC9B is ideal for Mil/Aero applications which require the proven survivability of the PowerXtreme family of boards.

Available in air- and conduction-cooled build levels, the PPC9B is fully supported by comprehensive Deployed Test Software (BIT and BCS) with OS support planned for VxWorks, LynxOS, Open Source Linux, and Integrity.



# PPC9B 6U VMEbus QoriQ P2020 based Single Board Computer

## Specifications

### Processor Node

- Support for Freescale QoriQ P2020 @ 1.2 GHz
- Two e500 cores
- 36-bit physical addressing
- Double-precision floating-point support
- Shared 512 KB L2 Cache with ECC

### DDR3 SDRAM

- Up to 2 GB DDR3 SDRAM with ECC
- 800 MB/s Data rate

### Flash Memory

- Up to 1 GB Flash memory
- 16 MB allocated for boot code, 8 MB per core (four independent 2 MB boot regions)

### VMEbus Interface

- 2eSST capable via TS1148 (ANSI/VITA 1.5-2003 offering bandwidths up to 320 MB/s)

### Gigabit Ethernet

- 3x Gigabit Ethernet (1 to front panel, 1 to P0, 1 to P2)

### Serial I/O

- 2x RS232 UART ports to P2
- 4x RS232/422/485 fast COM ports to P2

### USB

- 5x USB 2.0 (1 to front panel, 2 to P2, 2 to P0)

### SATA

- 2x SATA (150MB/s) to P2

### General Purpose I/O

- Up to 25 GPIO (18 on P2, 7 on P0), 5V tolerant GPIO each capable of generating an interrupt.

### Legacy Features

- Keyboard/Mouse (instead of USB on P2)
- Floppy or LPT port (instead of GPIO on P2)

### PMC Extension Slots

- One XMC/PCI-X PMC site with I/O routed to P0
- One PCI-X PMC site with I/O routed to P0/P2 (5V tolerant)

### NVRAM / Real-Time Clock / Watchdog / ETI

- 2x 128KB non-volatile NVRAM (FRAM)
- Real-time clock with 1 second resolution
- 2x Watchdog timers (programmable 64-bit timer)
- Elapsed Time Indicator (record power cycles and on-time)

### Temperature Sensors

- On-board ambient temperatures

### Power Requirements

- +5V required
- ±12V only if required by mounted PMC module

## Block Diagram

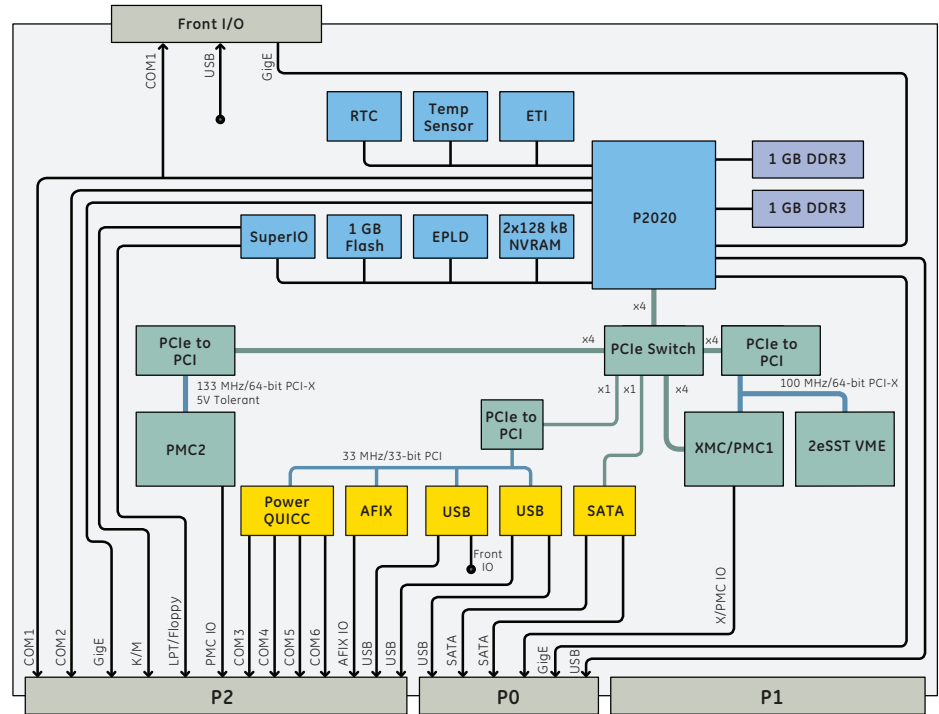

## Environmental

	Level 1	Level 2	Level 3	Level 4	Level 5
<b>Cooling Method</b>	Convection	Convection	Convection	Conduction	Conduction
<b>Conformal Coating</b>	Optional	Standard	Standard	Standard	Standard
<b>High/Low Temp</b>	0 to 55°C	-20 to +65°C	-40 to +75°C	-40 to +75°C	-40 to +85°C
<b>Operational</b>	(300 ft/m)	(300 ft/m)	(600 ft/m)	At cold wall	At cold wall
<b>Random Vibration</b>	0.002g <sup>2</sup> /Hz*	0.002g <sup>2</sup> /Hz*	0.04g <sup>2</sup> /Hz**	0.1g <sup>2</sup> /Hz**	0.1g <sup>2</sup> /Hz**
<b>Shock</b>	20g***	20g***	20g***	40g***	40g***

\*\*With a flat response to 1000 Hz, 6 dB/Oct roll-off from 1000 to 2000 Hz \*\* From 10 to 1000 Hz \*\*\*Peak sawtooth 11 ms duration

## About GE Intelligent Platforms

GE Intelligent Platforms, a General Electric Company (NYSE: GE), is an experienced high-performance technology company and a global provider of hardware, software, services, and expertise in automation and embedded computing. We offer a unique foundation of agile, advanced and ultra-reliable technology that provides customers a sustainable advantage in the industries they serve, including energy, water, consumer packaged goods, government and defense, and telecommunications. GE Intelligent Platforms is a worldwide company headquartered in Charlottesville, VA and is part of GE Home and Business Solutions. For more information, visit [www.ge-ip.com](http://www.ge-ip.com).

## GE Intelligent Platforms Contact Information

Americas: 1 800 433 2682 or 1 434 978 5100

Global regional phone numbers are listed by location on our web site at [www.ge-ip.com/contact](http://www.ge-ip.com/contact)

[www.ge-ip.com](http://www.ge-ip.com)

