

IC-e6-VMEa MPC7448 VME64x VITA 31.1 SBC

IC-e6-VMEa is a VME64x processor board based on the Freescale e600 processors. It is designed to provide the highest level of performance and integration available today.

The 2eSST capabilities of the **IC-e6-VMEa** provides up to 300MB/s transfer rate across the VMEbus. Moreover the backward compatibility protects existing investments.

The MPC7448 is a high-performance embedded e600 core. These low power PowerPC processors are ideal for application in the fields of defense, industrial automation and medical imaging.

IC-e6-VMEa can be used in many highly integrated applications like :

- Leading-edge computing.
- Embedded network control.
- Signal processing, etc.

Description

IC-e6-VMEa is powered by a MPC7448, being part of the PowerPC processor family. This processor features a high-frequency super scalar PowerPC core capable of issuing four instructions per clock cycle into 11 independent execution units : four integer units, one double-precision floating point unit, four AltiVec units, load/store and branch processing units. The MPC7448 provides 3900 DMIPS @ 1,7GHz. Owing to the Dynamic Frequency Switching, the core frequency can be changed "on the fly" to reduce the power consumption.

IC-e6-VMEa runs as a system controller or a standard board. An automatic detection can be used with the VME64x backplane. The VMEbus interface is based on a combination of the Tundra Tsi148 VME bridge and the latest generation of Texas Instrument transceivers. This design allows the switching speed required by the 2eSST protocol on all the backplane.

IC-e6-VMEa implements a DiscoveryTMIII chipset to fill out the processor. This solution includes major enhancements such as : data streaming on MPX bus, read memory latency and cache coherency improvements. The MV64460 indeed, adds 2 Mbits of high speed burst SRAM, two XOR DMA (useful for RAID, iSCSI) and four IDMA engines.

IC-e6-VMEa integrates many communication functions : three Giga Ethernet channels, one console port. An USB2 controller combined with a hub function provides three high/full speed ports. A quad UART provides four additional asynchronous channels available on P2.

The 64-bit PCI/PCI-X bridge allows the **IC-e6-VMEa** to control two PMC mezzanine boards.

Thanks to its optional SATA controller, **IC-e6-VMEa** can manage directly several storage devices.

IC-e6-VMEa can be used with many major RTOS and Linux.

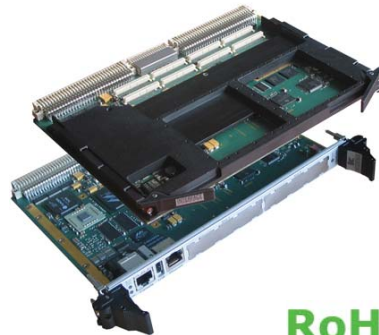

Main features

Processor Unit

- ▶ MPC7448 running at 1,4 or 1.7 GHz with :
 - L1 caches : 32KB Inst. and 32KB Data with parity.
 - 1MB of L2 integrated cache with ECC.
- ▶ 512MB or 1 GB of SDRAM-DDR with ECC.
- ▶ 64MB or 128MB of soldered Mirror Flash.
- ▶ Up to 1 GB soldered Nand Flash.
- ▶ 256KB (128-bit wide access) of high speed SRAM.
- ▶ 32KB of FRAM (non-volatile memory).
- ▶ PPC Real Time clock and four 32 bit-timers.
- ▶ Calendar clock with supercap backup.
- ▶ Temperature sensor and monitoring.

The MPC744A runs at 1GHz.

I/O subsystem

- ▶ VME64x with 2eSST (Tsi148).
- ▶ Two PMC slots with VITA35 routing : one Pn4 (64 IO) on P2 rows A/C, one partial Pn4 on P0.
- ▶ Marvell DiscoveryTM III system controller :
 - Three Ethernet 10/100/1000TX ports with :
 - support for Jumbo frames.
 - Virtual Cable Tester on line.
 - Two routed on rear P0 and one on front panel.
 - One serial interface for the front console port.
- ▶ One USB2 controller with a three ports internal hub.
- ▶ GPIO on P0
- ▶ A four channels SATA controller with two ports on P0 and two ports available through an on-board planar connector.

Accessories

- ▶ Engineering kit for debug : JTAG/COP, console cable, etc.
- ▶ 6U Rear Transition Module (RTM) providing : 2 Giga RJ45, USB2, four RS232/422 ports, two SATA connectors and an HD68 connector for the PMC IO.

IC-e6-VMEa is available in standard, extended and conduction-cooled grades.

IC-e6-VMEa

MPC7448 VME64x VITA 31.1 SBC

On-board firmware

Our basic firmware takes in charge Freescale's new MPC7448 (and the MPC7447A) and the Marvell chipset DiscoveryIII initialization. This on-board firmware, based on the open-source UBOOT, is an efficient set of software stored in a secured flash.

UBoot

It is called by the reset vector when the board is powered up. It initializes the PowerPC and the DiscoveryTMIII system controller, performs a comprehensive Power-on self-tests (PBIT), before jumping into different applications according to the values stored in memory. If the board acts as a Monarch PMC, the software executes an enumeration step, otherwise it waits for the PCI startup sequence from the host. In standalone mode the board directly runs the configured application.

The firmware allows loading files from Ethernet via Bootp, running files in RAM or flashing them. In addition, it allows some monitor functions such as : display or modify the RAM data. To end with, it enables the user to perform maintenance tests.

IC_Bios

This module allows the user to access the specific IC-e6-VMEa hardware resources via an easy-to-use API. This module is used as a library with Vxworks and as a dynamically loaded library module for Linux.

IC-BSP basic

These BSPs products are based on the standard distribution of the OS editor. They take in charge hardware initialization, interrupt handling and generation, hardware clock and timer services, memory management, PCI management, mapping of memory spaces, serial ports, MAC driver for Gigabit ports.

Interface Concept provides BSP for VxWorks® and Linux® operating systems. Other RTOS (LynxOS, Integrity...) can be ported on request.

Interface features

VMEbus 64x interface

- ▶ DTB Master : A16, A24, A32, A64 ; D08-D64, SCT, BLT, MBLT, 2eVME, 2eSST.
- ▶ DTB Slave : A16, A24, A32, A64 ; D08-D64, SCT, BLT, MBLT, 2eVME, 2eSST, UAT.
- ▶ Arbiter : RR/PRI
- ▶ Interrupt : handler/generator with IRQ[1..7]
- ▶ System controller with auto detect.

PMC slot

- ▶ Signaling : 3.3 and 5V tolerant.
- ▶ PCI , PCI-X 32/64-bit at 33, 66 or 100 MHz.
- ▶ Address/Data : A32/D32
- ▶ PMC IO routed on a/c rows of P2.

P0 connector

- ▶ 2 Giga Ethernet Compliant with Vita31.1.
- ▶ Two USB2
- ▶ Two SATA ports
- ▶ GPIO

The technology implemented on this board is also available on our IC-e6-CPIa (3U CompactPCI SBC) or on the IC-e6-cPC1b (6U model).

Block Diagram

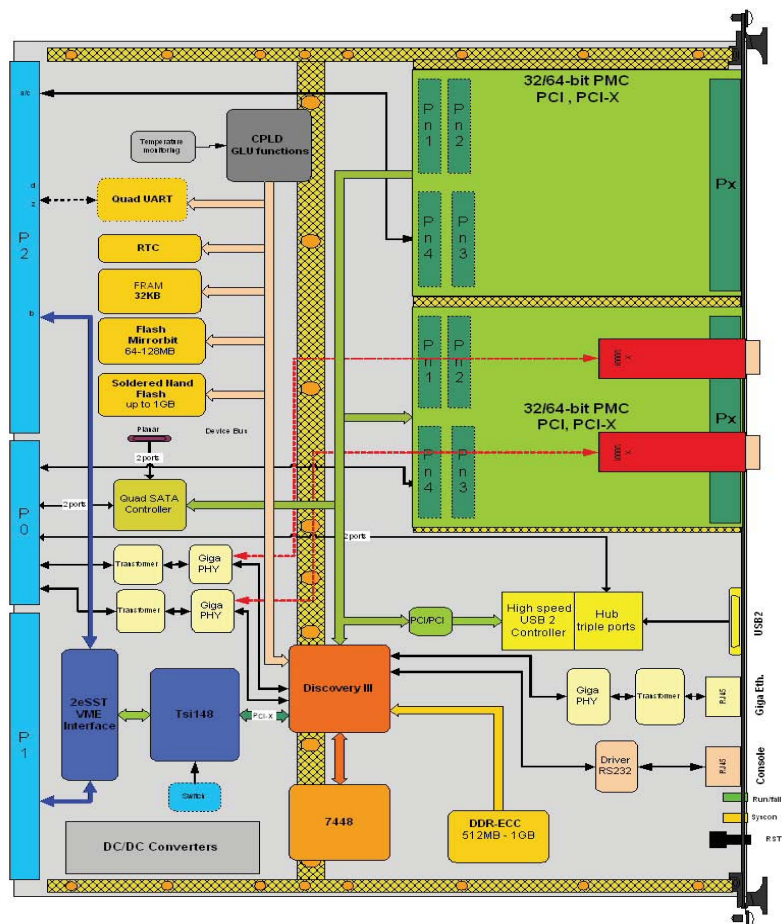

Environnement Specifications:

Please refer to information below.

Ordering Information:

Please consult the **IC-e6-VMEa datasheet** at www.interfaceconcept.com (listing all products reference and environment grades availability).

This document supersedes any earlier documentation relating to the products referred to herein. The information contained in this document is current at the date of publication. It may subsequently be updated or withdrawn without notice.

