



V4DSP

Dual Virtex-4 FX100 & PowerPC® 7448 6U VME2eSST Processor

Features

- 2 x Xilinx Virtex-4 FX100 FPGAs
 - QDR2 SRAM 2M x 36 bits
 - DDR2 SDRAM 2 banks 64M x 16 or 1 bank 64M x 32 bits per node
- MPC7448 PowerPC AltiVec
 - 256 MBytes PC266 DDR SDRAM
 - 64 MBytes Flash
- High Speed I/O
- Gigabit Ethernet
- Rugged 6U VME
- Layered Software Support
 - AXIS Advanced Multiprocessor Integrated Software
 - GE Built-In-Test / V-BIT
 - V-WRAP FPGA support
 - BSPs for VxWorks® & LynxOS®

V4DSP sets the standard for deployed COTS FPGA multiprocessors aimed at rugged defense and aerospace applications. The two Virtex-4 FX100s linked to the PMC/XMC and backplane via multi-gigabit transceivers (MGTs) offer maximum data bandwidth, while the onboard PowerPC 7448 provides system management and AltiVec floating point capability to complement the processing power of the configurable Virtex-4 nodes.

In addition, each FX100 node offers two PPC405 cores for additional processing and system management to facilitate a range of applications including signal and communications oriented data processing.

GE's layered software support includes AXIS optimized function libraries, inter-processor communication and productivity tools as well as board support packages (BSPs) for VxWorks 6.x, LynxOS and Built-In Test (BIT) for PowerPC.

Our V-WRAP FPGA support includes V-BIT, for power-on-self-test of the FPGA nodes as well as a selection of tested cores providing a quick start for the implementation of the required end-use design. V-WRAP can also support remote reprogramming of the FPGA image by the onboard 7448 processor or over network to an external host.

GE offers a range of multi-channel analog-to-digital PMC/XMCs that can be configured with the V4DSP. This combination provides a powerful, single slot solution for airborne, ground mobile and naval platforms. Further scalability is achievable over VME and StarFabric by linking to one or more G4DSPXD3 quad PowerPC7448 processors and the StarSwitch2 switch and PMC carrier cards.



V4DSP Dual Virtex-4 FX100 & PowerPC® 7448 6U VME2eSST Processor

Specifications

Two Xilinx Virtex-4 FX100 FPGAs

- QDR2 SRAM 2M x 36 bits per node
- DDR2 SDRAM 2 banks 64M x 16 or 1 bank 64M x 32 bits per node
- Platform FLASH 4 x 32 MBit/node
- User FLASH 2M x 32 MBit/node

MPC7448 PowerPC with AltiVec

- 256 MBytes PC226 DDR SDRAM
- 64 MBytes FLASH

High-Speed I/O

- Multi Gigabit Transceiver (MGT) ports between both Virtex-4 nodes, XMC and P0
- Two StarFabric ports to P0

Network

- Gigabit Ethernet Switch
 - Two ports to each Virtex-4
 - One port to the Disco2 bridge
 - One port to the P2 connector

Rugged 6U VME 2eSST form factor for air and conduction cooled systems.
 V-WRAP Virtex-4 EDK/ISE development package with preconfigured maintenance image and pre-tested cores. Offers quick start reference design with support for remote programming of FPGAs.

Block Diagram

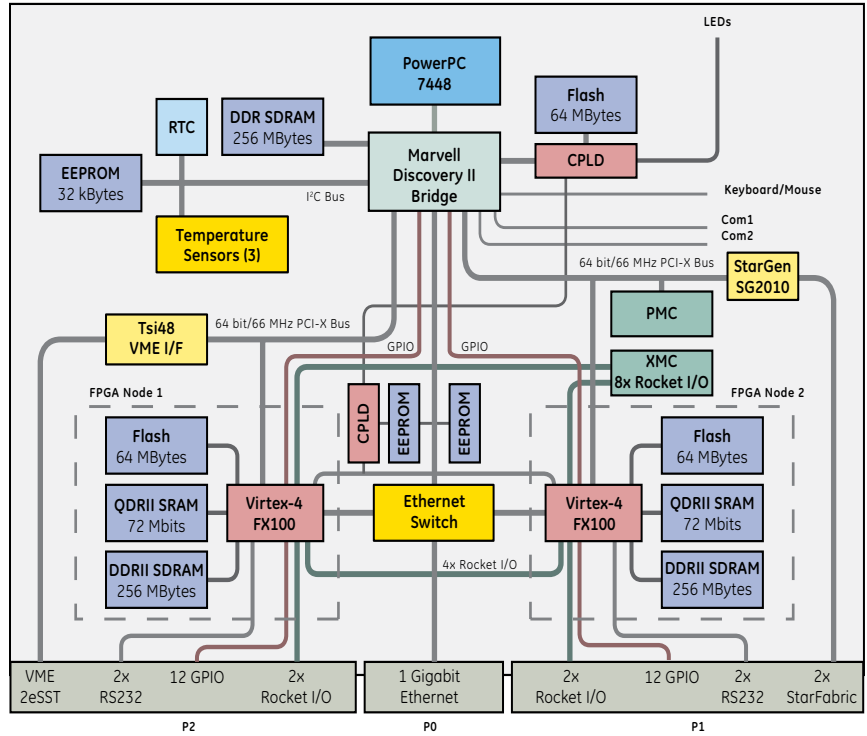

AXIS Multicomputer

Open Architecture, COTS Multiprocessor Solutions

Customer Application
AXIS Advanced Multiprocessor Integrated Software
Universal Interface Layer (UIL)
Board Support Package (BSP)
Built-in-Test (configurable POST)
I/O, SBCs, Multiprocessors, Fabric switches

Ordering Information

V4DSP-v81yz (v = build levels 1 to 5)

6U 2eSST VME FPGA card with 2 Virtex-4 FX100T nodes, local QDR2 SRAM, DDR2 SDRAM & FLASH with on-board 7448 PowerPC AltiVec™ with local SDRAM & FLASH, 1x XMC/PMC site & 2x StarFabric ports at P0.

Rear transition module must be ordered separately.

BIT & Board Support Package for VxWorks or LynxOS must be ordered separately.

About GE Intelligent Platforms

GE Intelligent Platforms, a General Electric Company (NYSE: GE), is an experienced high-performance technology company and a global provider of hardware, software, services, and expertise in automation and embedded computing. We offer a unique foundation of agile, advanced and ultra-reliable technology that provides customers a sustainable advantage in the industries they serve, including energy, water, consumer packaged goods, government and defense, and telecommunications. GE Intelligent Platforms is a worldwide company headquartered in Charlottesville, VA and is part of GE Home and Business Solutions. For more information, visit www.ge-ip.com.

GE Intelligent Platforms Contact Information

Americas: 1 800 433 2682 or 1 434 978 5100

Global regional phone numbers are listed by location on our web site at www.ge-ip.com/contact

www.ge-ip.com



AXIS™
Enabled Hardware