

CT12

High Performance Dual Core 6U CPCI Single Board Computer

Features

- Intel® Core™ i7 or Core i5 processors
 - Dual core, up to 2.53 GHz
 - Integrated memory interface, 1066 MHz
- Single slot 6U CPCI form factor
- PICMG® compliant
- Up to 8 Gbyte DDR3 SDRAM (dual channel) with ECC in main memory (soldered components)
- Up to 16 Gbyte NAND Flash (soldered)
- BIOS backup Flash
- User EEPROM
- Optional onboard SATA HDD
- Optional one or two PMC or XMC sites
- Front I/O:
 - Two Gigabit Ethernet ports
 - VGA
 - One USB
 - One COM 3
- Rear I/O:
 - Two Gigabit Ethernet ports
 - VGA 1
 - DVI 1 and 2
 - Three SATA interfaces
 - COM 1 and 2 ports
 - Four USB ports
 - GPIOs
 - PMC/XMC I/O signals

- IPMI 2.0 PICMG® 2.9
- Watchdog, temperature sensors
- OS support: standard distribution Linux® and Windows®
- Optional -40° C to +75° C operating temperature range
- Optional conformal coating
- Customization on request

The CT12 is a single slot 6U CompactPCI® SBC with an Intel® Core™ i7 processor plus QM57 peripheral controller hub. The assembly is fully compliant to the PICMG® specifications.

The CT12 is able to host one Dual Core processor with a core clock of up to 2.53 GHz. The assembly is ready to accept higher performance processor variants when introduced by Intel.

Four banks of DDR3 SDRAM components are provided on the CT12 for a maximum of 8 GBytes of main memory with ECC. The module also hosts up to 16 GByte soldered NAND Flash through an IDE interface and may be provisioned with higher Flash capacities when required for specific applications. The onboard NAND Flash is an ideal storage media to keep application specific data.

The BIOS Flash is optionally backed with a second Flash device in order to recover the BIOS in the event the primary BIOS is corrupted. The Flash device is large enough to optionally host additional pre-boot applications, for example Built-In Test (BIT).

For telecom applications, the CT12 is equipped with IPMI 2.0 functionality.

Supported operating systems for the CT12 include Linux® and Microsoft® Windows® as well as VxWorks.

The CT12 is also available in an extended operating temperature version (-40° C to +75° C). The upper limit of the temperature range depends on the selected processor version and the optional population with PMC, XMC mezzanines or a SATA hard drive.

The CT12 is designed for use in a broad range of applications such as telecom/communications, industrial control and automation, test, and measurement systems, as well as server blade applications. This, combined with a customer specific assembly service, provides optimized price and performance levels.

Please contact GE Intelligent Platforms for a current list of processors and OS versions supported on the CT12.



CT12 High Performance Dual Core 6U CPCI Single Board Computer

CT12 Safety and Reliability Benefits

Soldered processor and memory

Increased immunity against shock and vibration

Soldered NAND Flash drive

Higher immunity against shock and vibration compared to CompactFlash

BIOS Backup Flash

Fast recovery when BIOS upgrade got corrupted

Optional Built-In Test routines for platform integrity tests

HW Write Protect

Protects onboard code and data against unauthorized write access

Specifications

Processor – µFCBGA, Low Power Design

- Scalable embedded processing power
- 32 nm process
- Intel® Core™ i7 processor, up to 2.53 GHz
- Cache: up to 4 MB, full speed
- Dual core versions
- Low power processor versions
- Intel® Hyper-Threading technology (two threads per core)
- Intel® Turbo Boost support
- Fanless cooling with heat sink
- Two PCI Express x8 ports
- FDI and DMI interface to I/O Controller hub
- Contact GE Intelligent Platforms for current processor versions

Processor	Speed GHz	L2 MB	Memory MHz
i7-610E	2.53	4	1066
i7-620LE	2.00	4	1066
i7-620UE	1.06	4	800

CompactPCI

- PICMG 2.0 R3.0 compliant CPCI local bus standard
- 64-bit PCI for up to 8 slots (33 MHz) or 5 slots (66 MHz)
- Supports both system Host and Peripheral Mode in a single assembly
- 2 mm pin and socket connectors (IEC-1076-4-101)

I/O Controller Hub

- FDI and DMI interface to processor
- Supplies I/O interfaces/functions to front and rear
- 8 PCI Express ports
- Choice of four display channels

Main Memory Array

- Dual channel DDR3 SDRAM array: 4 banks soldered memory components
- 144-bit wide with error correction (ECC)
- Configurable capacity: 1 GByte to 8 GBytes

Flash ROM Memory

- Up to 16 GBytes NAND Flash
- Accessed by processor through IDE
- Soldered down for high reliability
- Wear leveling

Front Dual Gigabit Ethernet

- Twin Intel® 82574L PCI Express Ethernet controllers
- 10/100/1000BaseT auto-negotiation
- Ordering option

Rear Dual Gigabit Ethernet

- Twin Intel® 82574L PCI Express Ethernet controllers
- 10/100/1000BaseT auto-negotiation
- Compliant to PICMG® 2.16

Onboard Hard Disk or SSD Drive

- Optional internal 2.5" SATA hard disk or 2.5" SATA Solid State Drive (SSD)
- Usage of SSD is recommended for high shock and vibration immunity as well as extended temperature applications

PMC/XMC Extension Slots

- Optional as PMC or XMC extension slots
- Optional one or two extension slots
- Extension slot 1: PMC (64-bit PCI, up to 133 in PCI-X mode) or XMC with PCI Express x8 (Gen2, 2.5 Gbit/s)
- Extension slot 2: PMC (64-bit PCI, up to 133 in PCI-X mode) or XMC with PCI Express x8 (Gen2, 2.5 Gbit/s)
- Extension slot 2 is not available in case a 2.5" storage device is installed
- PCI signaling is 3.3V, 5V tolerance

Serial I/O

- Two async. 16550 compatible full duplex serial channels
- High-speed transfer up to 115.2 kbaud with 16 byte FIFOs
- User selectable RS-232/422/485 interfaces at rear
- COM3 RS-232 available at front via HarLink® connector

Video/Graphics Interface

- Intel integrated 3D graphics controller
- One VGA port at front via HarLink connector
- One VGA port plus two DVI-D ports at rear I/O
- Any two ports can be used for dual display operation
- Fully compliant support for OpenGL™ for all Windows operating systems and Linux

General Purpose I/O

- 13 GPIO (input or output) pins
- Software configurable
- Hardware Write Protection of programmable devices

USB Ports

- One USB 2.0 connector on the front
- Four USB 2.0 channels on rear

Keyboard and Mouse

- Via USB
- Legacy PS/2 controller emulation

Real-time Clock

- RTC 146818 compatible
- Li-battery

EEPROM

- 512 kbit serial EEPROMs for non-volatile user data

Timer

- Integrated in Hub controller
- Legacy PC-AT timer
- HPET High Precision Event Timer

Watchdog

- Super I/O

Temperature Sensors

- CPU die and chipset die temperature software readable in the range of -15°C to +105°C

LED

- Front panel ACPI system Status indicator LED (red/amber/green)
- CompactPCI Hot swap (blue) on front panel

Hot-Swap - compliant to PICMG 2.1

- Peripheral mode: full CompactPCI Hot Swap
- System Host mode: CompactPCI ENUM# event support through ACPI or legacy driver

Front and Rear I/O (Transition Module CTM20)

Function	Front	Rear
VGA 1		•
VGA 2	•	
DVI 1 & 2		•
COM 1	•	•
COM 2		•
USB 0 – 3		•
USB 4	•	
Ethernet 1,2	•	
Ethernet 3,4		•
SATA 2		• ¹
SATA 3-5		•
GPIO		•
LEDs	•	•
PMC 1 / XMC 1 I/O	•	•
PMC 2 / XMC 2 I/O	•	•
Reset	•	•

¹ If Flash ROM option is not used

BIOS Features

- New AMI Aptio UEFI, in-system programmable Flash ROM
- CPU, memory and SATA auto-detection/selection
- Integrated Ethernet PXE driver
- USB mass storage support and booting capability (floppy, HDD, CDROM, and onboard Flash ROM array)
- Password protection
- Headless operation

IPMI 2.0

- Baseboard Management Controller supporting the Intelligent Platform Management Interface (IPMI) architecture in compliance with PICMG® 2.9
- Peripheral mode and BMC mode are supported
- IPMI is an optional function

Software

- Windows
- Linux
- VxWorks

Styles

Style	A	F
Ext. Temperature	no	yes

Conformal coating is a custom option.

CT12 High Performance Dual Core 6U CPCI Single Board Computer

Specifications (continued)

Power Requirements

- +5 V, +3.3V, +12V
- 12V if required by mounted PMC module

Power Allowances – PMC/XMC Slots

- +5 V, +3.3 V: Total power max. 7.5 W
- ±12 V: 100mA each

Power Consumption – typical operating current

- Without keyboard, hard disk, Windows, 3D graphics active, Gigabit Ethernet channels not active, measured at DOS prompt, no power savings. 1 GB memory option – see manual.

Temperature

- Note: Consult the User's Manual or GE Intelligent Platforms for additional detailed information on the operating temperature behavior of the module. The CT12 operating temperature range is influenced by processor type and speed, operating altitude, and the type of cooling used in the host system.
- All values under typical conditions without PMC/XMC module.

Range	Operating	Storage
Standard	0° C to +55° C	-40° C to +85° C
Extended	-40° C to +75° C	-40° C to +85° C

	Operating	Storage
Humidity	5 - 95% @ 40° C	5 - 95% @ 40° C
Altitude	15,000 ft. (4.5 km)	40,000 ft. (12 km)

Block Diagram

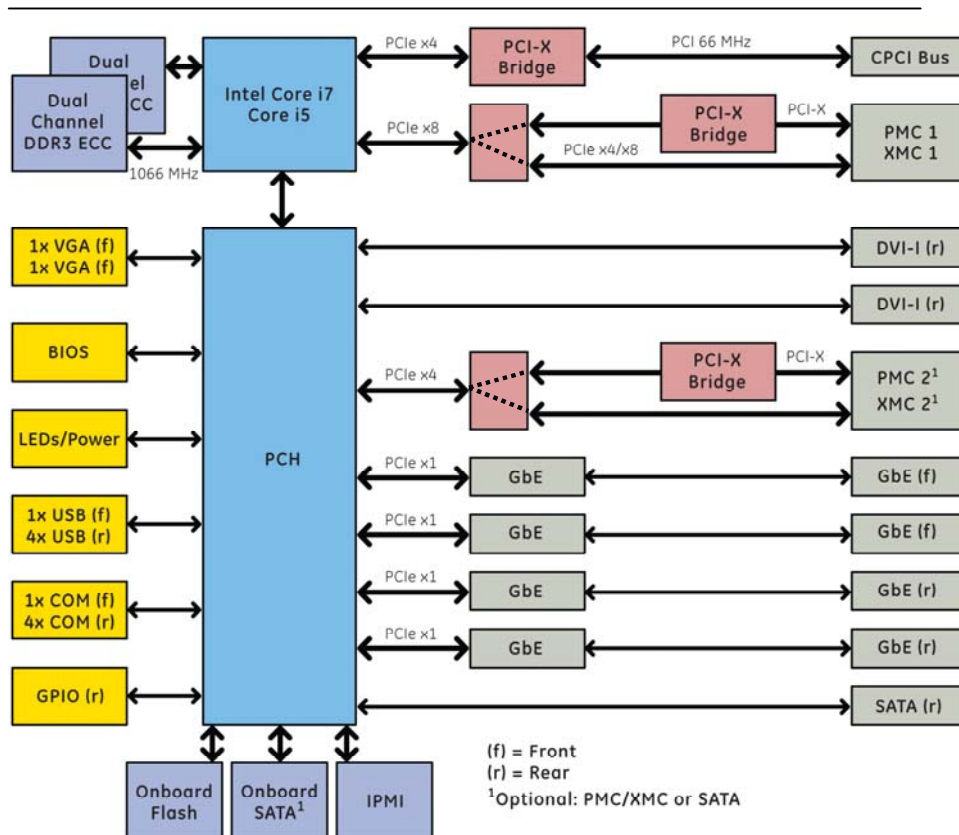

Mechanical – PICMG 2.0

- 6U, 1 slot wide, 233 mm x 160 mm x 20 mm with Flash drive or hard disk

Altitude

- Operating: Sea level to 15,000 ft. (4.5 km)
- Storage: Sea level to 40,000 ft. (12 km)

Shock and Vibration

- Designed to meet VITA47 class EAC1 and EAC3

MTBF

- Prediction calculations are available in accordance with MIL-HDBK-217. Please contact GE Intelligent Platforms.

Safety

- Designed to meet standard UL1950, CE class A, FCC-A

Ordering Information

CT12AUF2K10A	6U cPCI PC, single slot, Core i7-610E 2.53 GHz, 4 GB DDR3, 4 GB NAND drive, 2x front GigE, 2x rear GigE, 2x SATA, VGA (front), COM (front), VGA (rear), 2x COM (rear), 2x USB (rear), 4x SATA (rear)
CT12CUF2K10A	6U cPCI PC, single slot, Core i7-620LE 2.0 GHz, 4 GB DDR3, 4 GB NAND drive, 2x front GigE, 2x rear GigE, 2x SATA, VGA (front), COM (front), VGA (rear), 2x COM (rear), 2x USB (rear), 4x SATA (rear)
CTM20A10A	6U I/O transition module for CT12 without onboard SATA drive with all onboard and face plate I/O ports.
YLB-CR12-01	Front I/O COM port cable (appr. 200 mm), Harlink connector to serial connector
YLB-CR12-02	Front I/O VGA port cable (appr. 200 mm), Harlink connector to VGA connector
CR12-SDK-LINUX	System Development Kit for Linux (Fedora 12, RHEL 5.4, Suse 11.2)
BVXW-CRCT12-01M	Board Support package for Workbench/VxWorks 6.x with maintenance
TVXW-CRCT12-01M	Board Support Package and Enhanced Support package for Workbench/VxWorks 6.x with maintenance
VXW6-ECR12	VxWorks 6.x Board Support Package (BSP) and Extended Board Support Package (ESB)
CR12-SDK-WIN	System Development Kit for Windows XP, (planned Windows7)

Operating Systems For detailed information and further options, contact GE Intelligent Platforms.

GE Intelligent Platforms Contact Information

Americas: 1 800 322 3616 or 1 256 880 0444

Global regional phone numbers are listed by location on our web site at www.ge-ip.com/contact

www.ge-ip.com

