

IMP3A

3U CPCI QorIQ-based Single Board Computer

Features

- Freescale QorIQ processor up to 1.2 GHz
 - Two e500v2 cores
 - Shared 512 KB L2 Cache with ECC
 - Integrated DDR3 memory controller with ECC
- Up to 4 GB DDR3 SDRAM with ECC
- Up to 2 GB NAND Flash and 128 KB of NVRAM
- One PCI-X PMC expansion site
- Rear IO
 - 2x Gigabit Ethernet
 - 2x COM ports
 - 1x USB 2.0 ports
 - 2x SATA ports
 - Up to 64x PMC IO
 - 16x GPIO
- Operating system support for VxWorks®, and Linux®
- Single slot 3U CompactPCI form factor
- Compliant to PCIMG® 2.0 R3.0

The IMP3A is the first Freescale QorIQ-based single board computer to join the PowerPact3 family of 3U CompactPCI processors. This product is designed for demanding applications where size-, weight-, and power-constraints (SWAP) are critical to success. With the new P2020 and P2010 processor options the IMP3A will deliver unparalleled performance in a single slot solution.

Features of the QorIQ P2 processor are:

- System on Chip (SoC) processors with high-performance e500 cores built on Power Architecture Technology
- 45 nanometer technology delivers unprecedented performance per watt, enabling power-efficient designs
- Dual- and single-core products

The IMP3A is offered with an impressive range of I/O that includes two Gigabit Ethernet channels, up to 16 GPIO, two SATA channels, two COM ports, and USB 2.0.

The IMP3A can be factory configured as either a system slot SBC supporting 46 pins of PMC I/O to J2, or a peripheral slot SBC supporting 64 pins of PMC I/O to J2.

Available in air- and conduction-cooled build levels, the IMP3A is fully supported by comprehensive Deployed Test Software (BIT and BCS) and support planned for popular real time operating systems including VxWorks, Integrity and LynxOS®.



IMP3A 3U CPCI QorIQ-based Single Board Computer

Specifications

Processor

- Support for Freescale QorIQ P2020 and P2010 operating at 1.2 GHz
- Two e500v2 cores
- 36-bit physical addressing
- Double-precision floating-point support
- Shared 512 KByte L2 Cache with ECC

DDR3 SDRAM

- Up to 4 GByte DDR3 SDRAM with ECC
- 800 MByte/s data rate

Flash Memory

- Up to 512 MByte NOR Flash memory
- Up to 2 GByte NAND Flash
- 16 MBytes allocated for boot code, 8 MBytes per core
 - Each 8 MBytes feature four independent 2 MByte boot regions

CompactPCI Interface

- PICMG 2.0 R3.0 compliant capable of 33 MHz and 66 MHz
- 5V and 3.3V VIO supported
- System controller and peripheral modes supported

Gigabit Ethernet

- 2x Gigabit Ethernet to P2
- 10/100baseT also supported

Serial I/O

- 2x RS232/422 COM ports to P2

USB

- 1x USB 2.0 to P2

SATA

- 2x SATA (150MB/s) to P2

General Purpose I/O

- 16 GPIO, all of which are 5V tolerant, each capable of generating an interrupt.

PMC Extension Slot

- One IEEE-P1386 (level 1-3) and VITA 20-2001 (levels 4-5)
- All levels are compliant to IEEE-P1386.1 (PMC) and VITA 39-2003 (PCI-X PMC)
- PMC site is both 5V and 3.3V tolerant
 - 64-bit/133 MHz PCI-X supported
 - 64 I/O pins to J2 in peripheral-only mode
 - 46 I/O pins to J2 in system slot/peripheral mode

NVRAM/Real-Time Clock/Watchdog/ETI

- 128 KByte non-volatile FRAM
- Real-time clock with 1 second resolution
- 2x Watchdog timers (programmable 32-bit timer)
- Elapsed time indicator (record power cycles and on-time)

Temperature Sensors

- On-board ambient temperatures

Power Requirements

- +5V and 3.3V required
- ±12V only if required by mounted PMC module

Block Diagram

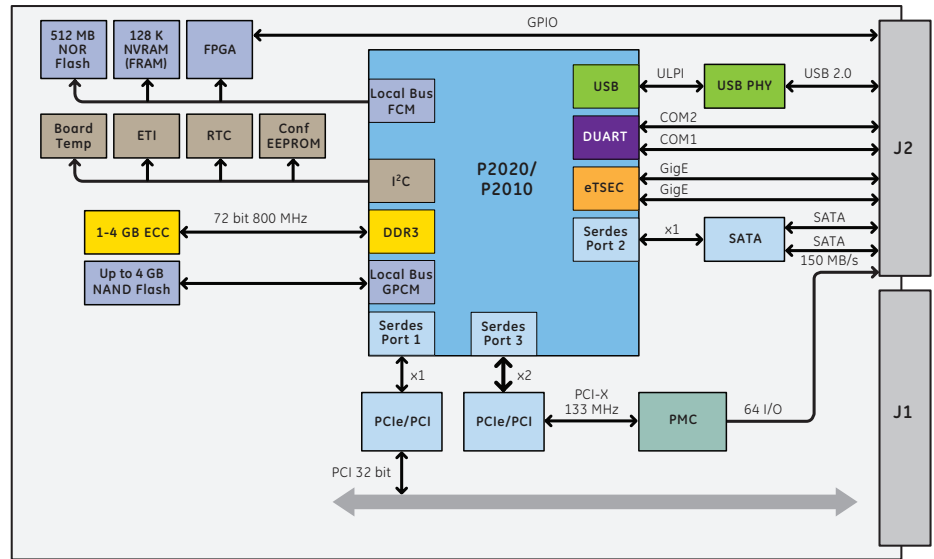

Environmental

	Level 1	Level 2	Level 3	Level 4	Level 5
Cooling Method	Convection	Convection	Convection	Conduction	Conduction
Conformal Coating	Optional	Standard	Standard	Standard	Standard
High/Low Temp	0 to 55°C	-20 to +65°C	-40 to +75°C	-40 to +75°C	-40 to +85°C
Operational	(300 ft/m)	(300 ft/m)	(600 ft/m)	At cold wall	At cold wall
Random Vibration	0.002g ² /Hz*	0.002g ² /Hz*	0.04g ² /Hz**	0.1g ² /Hz**	0.1g ² /Hz**
Shock	20g***	20g***	20g***	40g***	40g***

With a flat response to 1000 Hz, 6 dB/Oct roll-off from 1000 to 2000 Hz ** From 10 to 1000 Hz *Peak sawtooth 11 ms duration

About GE Intelligent Platforms

GE Intelligent Platforms, a General Electric Company (NYSE: GE), is an experienced high-performance technology company and a global provider of hardware, software, services, and expertise in automation and embedded computing. We offer a unique foundation of agile, advanced and ultra-reliable technology that provides customers a sustainable advantage in the industries they serve, including energy, water, consumer packaged goods, government and defense, and telecommunications. GE Intelligent Platforms is a worldwide company headquartered in Charlottesville, VA and is part of GE Home and Business Solutions. For more information, visit www.ge-ip.com.

GE Intelligent Platforms Contact Information

Americas: 1 800 433 2682 or 1 434 978 5100

Global regional phone numbers are listed by location on our web site at www.ge-ip.com/contact

www.ge-ip.com

