

# CL11

## High Performance – 3U Compact PCI® Single Slot Dual Core Processor Board

### Features

- Intel® Core 2 Duo® processor, 1.5 GHz
- Intel® Core Duo® processor 1.2, 1.66 and 2 GHz
- Up to 4 MByte L2 cache
- Ultra compact all-in-one PC
- Single slot
- System or non-system (peripheral mode)
- System slot for 32-bit CompactPCI backplane
- Up to 2 GByte DDR2 SDRAM
- Optional Flash drive
- VGA interface
- Dual Gigabit Ethernet
- Enhanced IDE UDMA-100
- 2x Serial ATA
- 1x serial I/O with FIFOs, RS-232 interface
- 6x USB 2.0
- Watchdog, temperature sensor
- 5 V / 3.3 V supply
- Optional -40 °C to +75 °C
- Custom specific versions
- RoHS compliant

CL11 is a high-performance, single slot, 3U CompactPCI CPU board using the Intel Core Duo or the Intel Core 2 Duo Processor. It incorporates sophisticated power management technology, eliminating the need for an onboard fan. The CL11 can be ordered as a system or non-system slot single board computer

CompactFlash is available as an option.

The CL11 supports two Gigabit Ethernets, up to 2 GByte of DDR2 SDRAM and VGA. At the core of the CL11 design is a high-bandwidth bus between the processor, and the chipset is running with a FSB of up to 667 MHz. The chipset-to-memory bus supports 667 MHz (PC2-5300) DDR2 SDRAMs. In addition there are six USB 2.0 ports, one serial channel, and two serial ATA channels. Interfaces are available as front- and/or rear-I/O. The CL11 is available in

standard temperature range 0 °C to +70 °C or optional extended temperature range from -40 °C to +75 °C. Custom specific versions are available on request.

The CL11 is a powerful processor platform for a wide range of applications and markets such as multimedia, automation, transportation, as well as imaging, medical, robotics, and many others. The CL11 is very suited to low-power embedded computer applications in a small form factor where optimal performance and functionality is required.

The CL11 is RoHS compliant.

For additional functionality, refer to the CL11's sister product, CC11. The CC11 is a 3U Compact-PCI dual slot dual core processor board.



# CL11 High Performance – 3U Compact PCI® Single Slot Dual Core Processor Board

## Specifications

### Processor – µFCBGA, Low Power Design

- Scaleable processing power with flexible processor design
- Intel Core Duo processor U2500: 1.20 GHz
- Intel Core Duo processor L2400: 1.66 GHz
- Intel Core Duo processor T2500: 2.00 GHz
- Intel Core 2 Duo processor L7400: 1.5 GHz
- High efficiency on-board switching regulator (DC/DC)
- Fanless cooling with heat sink
- \* Contact factory for latest CPU versions

Cache	level 1	level 2e
Core Duo	32 KByte	2 MByte, full speed
Core 2 Duo	32 KByte	4 MByte, full speed

### Chipset – Intel 945GM with Intel ICH7R

- 533/667 MHz system bus to processor
- One PCI Express x4 interface
- Two PCI Express x1 interfaces
- Data throughput between 945GM and ICH7R is theoretically 2 GByte/s (1 GByte/s each direction)

### Memory – DDR2 667

- Single-/dual-channel DDR2 SDRAM
- High-speed 667 MHz (PC2 5300) DDR2 SDRAM
- 64-bits wide/128-bits wide
- 512 MByte to 2 GByte with soldered chips

### CompactPCI

- PICMG 2.0 R3.0 compliant CPCI 32 bit/66 MHz local bus standard
- Backplane with rear I/O
- System or non-system (peripheral) PCI Bridge Pericom PI7C9X110 for up to 7 slots
- J1+2, 2 mm pin and socket connectors (IEC-1076-4-101)

### Gigabit – Two Realtek RTL8111B

- Highly integrated single Gigabit Ethernet controller with PCI Express x1 interface
- 64 KB transmit and receive FIFO
- 10/100/1000BaseT auto-negotiation
- Port 1 and Port 2 for front or rear I/O. Solder option.

### Flash Drive

- EIDE interface on header connector
- Extension board with one CompactFlash connector

### VGA and LCD - Chipset Integrated

- 2D & 3D graphics engine
- DirectX 9.1 support
- Up to 64 MB of dynamic video memory allocation
- Integrated 360 MHz 24-bit RAMDAC for analog VGA monitors up to 1600 x 1200, 75 Hz
- Display image rotation
- Graphics power management

- VGA at front or rear I/O

### EIDE

- Ultra ATA/100 sync. DMA mode up to 90 MByte/s
- PIO mode 4 and bus master IDE up to 16 MByte/s
- Onboard devices supported via local header

### SATA

- Two serial ATA at rear I/O
- DMA mode up to 150 MByte/s

### Serial I/O - RS232

- Integrated in SMSC SCH3112 Super I/O
- One asynchronous 16550 compatible full duplex serial channel
- High-speed transfer up to 115.2 Kbaud with 16 byte FIFOs
- COM1 available at rear I/O

### General Purpose Input/Outputs

- Integrated in SMSC SCH3112 Super I/O
- 8 bits programmable general purpose inputs/outputs

### USB 2.0

- Six USB 2.0 connectors. Two on front, three on rear I/O and one onboard

### Keyboard

- Via USB (supports legacy keyboard/mouse SW)

### Mouse

- Via USB (supports legacy keyboard/mouse SW)

### Real-time Clock

- Integrated in chipset
- RTC 146818 compatible, on-board Li-battery

### CMOS RAM

- 114 bytes non-volatile CMOS RAM for BIOS data

### EEPROM

- 512 Kbit (64 KByte) serial EEPROM for non-volatile user data

### Floppy

- Via USB port

### Watchdog

- Integrated in chipset
- Two-stage watchdog with independent count values
- First stage drives NMI or SMI, second stage drives reset
- Configurable granularity from 1 µs to 10 min

### Timer

- Integrated in chipset based on 82C59
- Includes three timer comparators
- One-shot and periodic interrupts supported

### Temperature Sensor

- CPU die and heat sink temperature software readable from -65 °C to +127 °C



# CL11 High Performance – 3U Compact PCI® Single Slot Dual Core Processor Board

## LED

- Two LEDs at front panel

## BIOS Features

- New AMI BIOS Core 8, in-system programmable Flash ROM
- Automatic system configuration
- Integrated VGA, SATA RAID and Ethernet PXE ROM
- USB mass storage support
- Password protection
- Headless support
- Remote console through serial port

## Software

- The following software is supported to the extent listed below.

OS	On Request	Available
WIN XP	-	√
QNX 6	√	-
VxWorks	-	√
Lynx OS	√	-
Linux	√-	√

## Front and Onboard I/O with Standard Front Panel

Function	Single Board Computer CC11		
	Front I/O	Onboard I/O	Rear I/O
Gb Ethernet 0	RJ-45 *2		Yes *2
Gb Ethernet 1	RJ-45 *2		Yes*2
USB 0	USB		
USB 1	USB		
USB 2 to 4			Yes
USB 5		Misc. Header 2	
VGA	D-15		Yes
EIDE		Misc. Header 1 *1	
SATA 1 / 2			Yes
COM 1			Yes
GPIO (8 pins)			Yes
Power button	Button Yes		Reset
Speaker			Yes
LED	Yes		
Keyboard, Mouse, Floppy	Via USB		Via USB

\*1 CompactFlash adapter with special extension

card possible

\*2 Front- or Rear-I/O as a solder option

## Power Requirements

- +5 V, +3.3 V Required

## Power Consumption – typical operating current (est)

- TBD

## Mechanical – PICMG 2.0

- 3U, 1 slot wide (100 x 160 x 20.32 mm) with front panel

## Temperature

- Note: For detailed information about the operating temperature behavior of the board it is absolutely necessary to consult the manual. The highest achievable operating temperature depends on processor type, speed, ambient conditions (air flow) and front plate width.
- All values under typical conditions.

	Operating	Storage
Standard	0 °C to +55 °C	-40 °C to +85 °C
Extended	-40 °C to +75 °C	-40 °C to +85 °C

## Humidity

- Operating: 5% – 95% @ 40 °C
- Storage: 5% – 95% @ 40 °C

## Altitude

- Operating: 15.000 ft. (4.5 km)
- Storage: 40.000 ft. (12 km)

## Shock (3 axis, up & down, 5 hits/direction)

- Styles 1, 3: 12 g /6 ms

## Vibration (60 minutes each axis)

- Styles 1, 3: 2 g rms @ 5 to 100 Hz

## VITA 47

- Designed to meet VITA47 class EAC1 and EAC3

## MTBF

- Calculations are available in accordance with MIL-HDBK-217.  
Please contact GE Intelligent Platforms.

## Safety

- Designed to meet standard UL1590, CE Class A, FCC-A



# CL11 High Performance – 3U Compact PCI® Single Slot Dual Core Processor Board

## Block Diagram

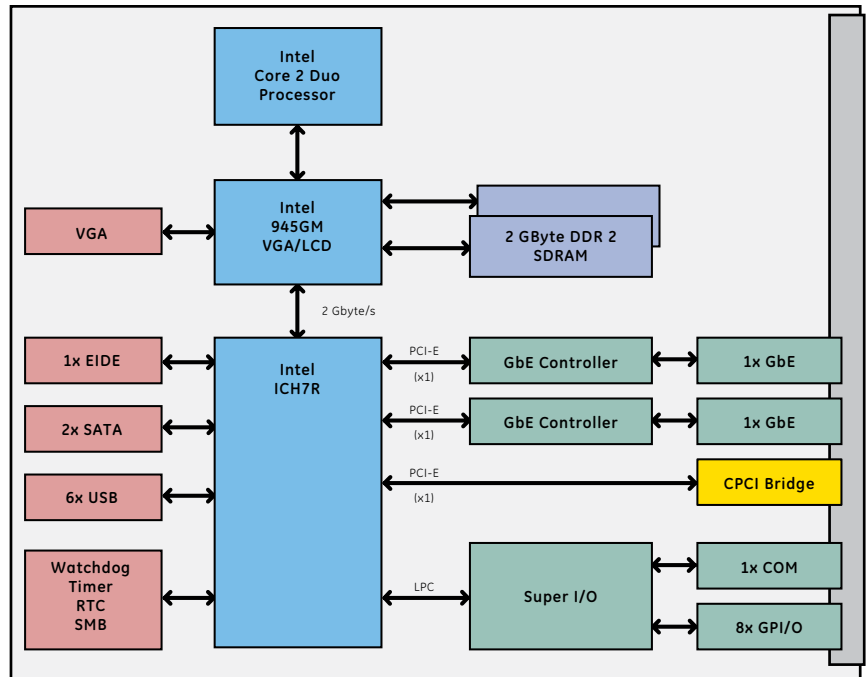

## Ordering Information

### Hardware Accessories

CTM18 /O transition module for 3U backplane

SCC484TB05CL11R Starter cage 19" 4U, 5 slots, with fans, power supply, CDROM and hard disk, 0° C to +40°C

### Operating Systems

Extensive operating systems support is available, (see page 3 of this document).

Chassis with power supplies, backplanes and drives on request.

For detailed information and further options, contact GE Intelligent Platforms.

## About GE Intelligent Platforms

GE Intelligent Platforms, a General Electric Company (NYSE: GE), is an experienced high-performance technology company and a global provider of hardware, software, services, and expertise in automation and embedded computing. We offer a unique foundation of agile, advanced and ultra-reliable technology that provides customers a sustainable advantage in the industries they serve, including energy, water, consumer packaged goods, government and defense, and telecommunications. GE Intelligent Platforms is a worldwide company headquartered in Charlottesville, VA and is part of GE Home and Business Solutions. For more information, visit [www.ge-ip.com](http://www.ge-ip.com).

## GE Intelligent Platforms Contact Information

Americas: 1 800 433 2682 or 1 434 978 5100

Global regional phone numbers are listed by location on our web site at [www.ge-ip.com/contact](http://www.ge-ip.com/contact)

[www.ge-ip.com](http://www.ge-ip.com)

